

T2



USER MANUAL

PN: 21-0122_REV03



TWISTERTRIMMER.COM



TWISTERTRIMMER.COM

TABLE OF CONTENTS

Important Safety Information	2
Machine Overview	5
Initial Setup	8
Control Panel Overview	13
Operation	14
Disassembly	16
Reassembly	20
Inspections	24
Cleaning	27
Maintenance	28
Storage	39
Troubleshooting	40
Warranty Information	48
Specifications	50
Accessories	52
Contact Us	54

This manual is for the Twister T2 Trimmer. In this manual, the T2 Trimmer will simply be referred to as the T2.

The T2 is a high-speed cutting machine requiring special safety precautions to be practiced during operation and maintenance to reduce the risk of personal injury. Please read this manual including all important safety information, danger, warning, and caution signs before using the T2.

Keirton is continually improving all of its products. As a result, engineering changes are sometimes made. If operation or appearances differ from this manual, please contact Keirton Technical Support for assistance (for contact details, see page 54).

All first-time users of the T2 should obtain proper instruction from this manual.

General Safety Information

- Do not move, disassemble, clean, or inspect the T2 while power is connected to the machine.
- Ensure all protective covers are installed and hands are clear of the machine before plugging in the T2.
- Ensure the vacuum hose is connected to the vacuum shroud outlet on the T2 before connecting the T2 to power.
- Do not reach inside the tumbler while the T2 is plugged in.
- Do not allow water to collect on the ground around the T2. This could cause a slipping hazard.
- Keep body parts away from moving parts of the T2.
- The T2 is heavy. Never lift alone, and always use proper lifting technique.



DANGER

CARELESS USE OF THE T2 OR OPERATING IT WITHOUT READING THE INSTRUCTIONS AND ACCOMPANYING DANGER, WARNING, AND CAUTION NOTICES MAY RESULT IN SERIOUS OR FATAL INJURY.

- Substituting factory parts with third-party parts may result in bodily harm or damage to the T2.
- Keep the T2 well ventilated to prevent overheating.
- Safety glasses, dust masks, and ear protection must be worn when operating the T2.
- Do not wear loose clothing or jewellery when operating or conducting maintenance on the T2.
- Confine long hair when operating or conducting maintenance on the T2.
- Do not operate or conduct maintenance on the T2 while tired or under the influence of drugs, alcohol, or medications.
- Do not remove safety labels from the machine. **Replace any safety labels if they become damaged or obscured.**

Connection & Electrical Safety Information

- The T2 requires a 120V, 20A (North America) or 230V, 10 A (Europe) circuit breaker.
- The T2 must be used in connection with a properly grounded receptacle. Refer to the specifications (see pages 50-51) to determine the correct electrical requirements.
- Observe all applicable building and electrical codes.
- Do not overload outlets or extension cords as this can result in fire or electric shock.
- Do not use extension cords lower than 12 AWG.
- Do not use extension cords longer than 25ft (7.5m).
- To power down the T2, switch off the motors via the control panel before unplugging the machine.

Operation Safety Information

- Ensure the T2 is fully assembled before operation.
- Do not operate the T2 without the vacuum hose installed.
- Keep visitors and children a safe distance from the T2.
- Never let the T2 run unattended.

- **Only place plant matter in the T2.** Do not put foreign objects in the T2. Doing so may cause bodily harm or damage to the machine.

Maintenance

- Conduct regular maintenance on the T2.
- Ensure the T2 is powered off and the machine is unplugged before conducting any maintenance, repairs, or cleaning. **Never conduct maintenance, repairs, or cleaning while the T2 is plugged in.**
- Do not attempt to service electrical components on the T2 yourself; opening or removing covers may expose you to dangerous voltage and possible fire or electric shock.
- Do not attempt service not covered in this manual unless directed by technical support.
- Some repair or damage will require a qualified service technician who is trained in machinery maintenance, service, and repair.
- Improper adjustment may result in damage to the machine.
- Replacement parts are specific to the T2 and must only be purchased from an authorized dealer. Failure to comply may void warranty, cause bodily harm, and/or damage to the machine.

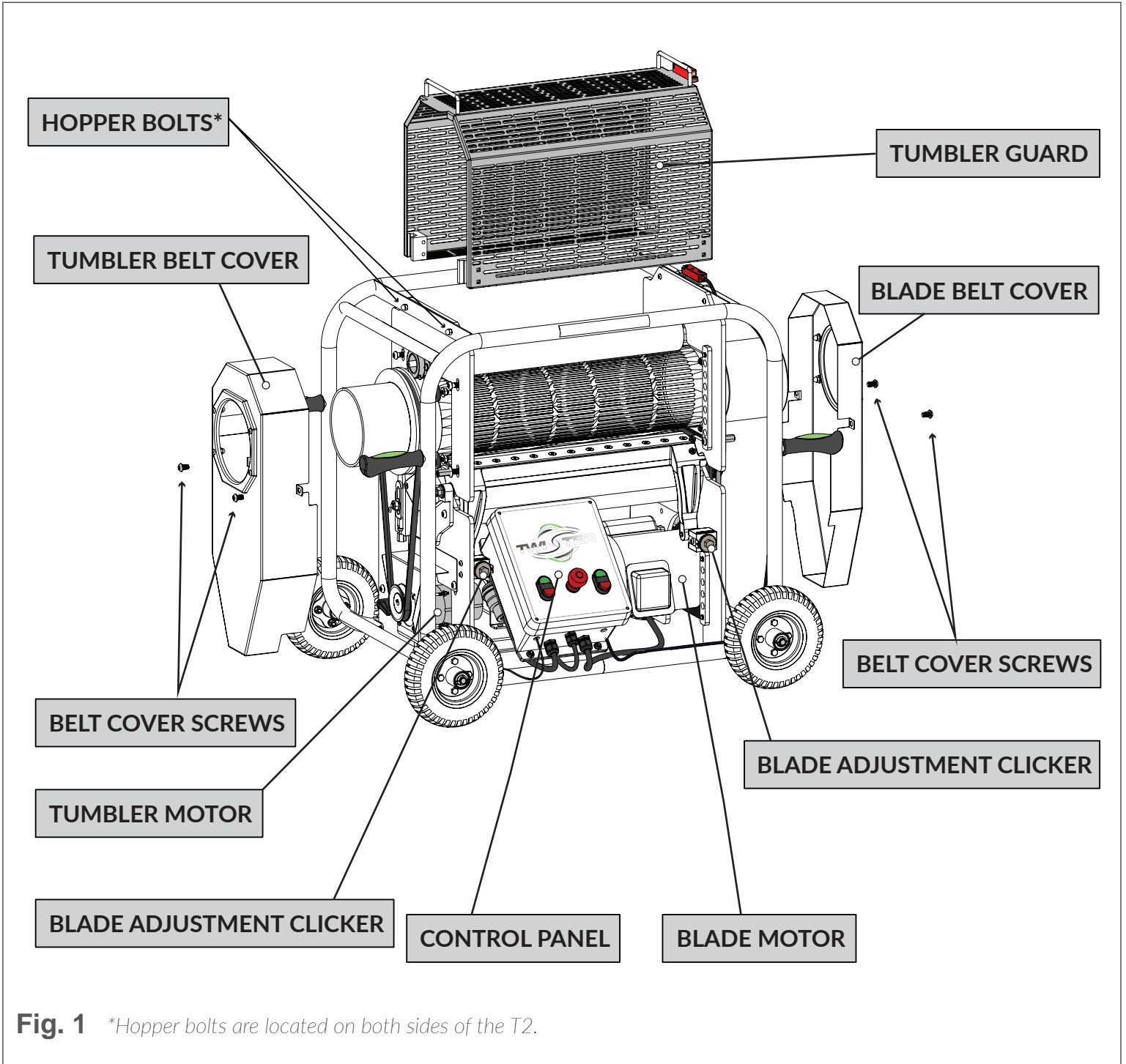

Fig. 1 *Hopper bolts are located on both sides of the T2.

MACHINE OVERVIEW

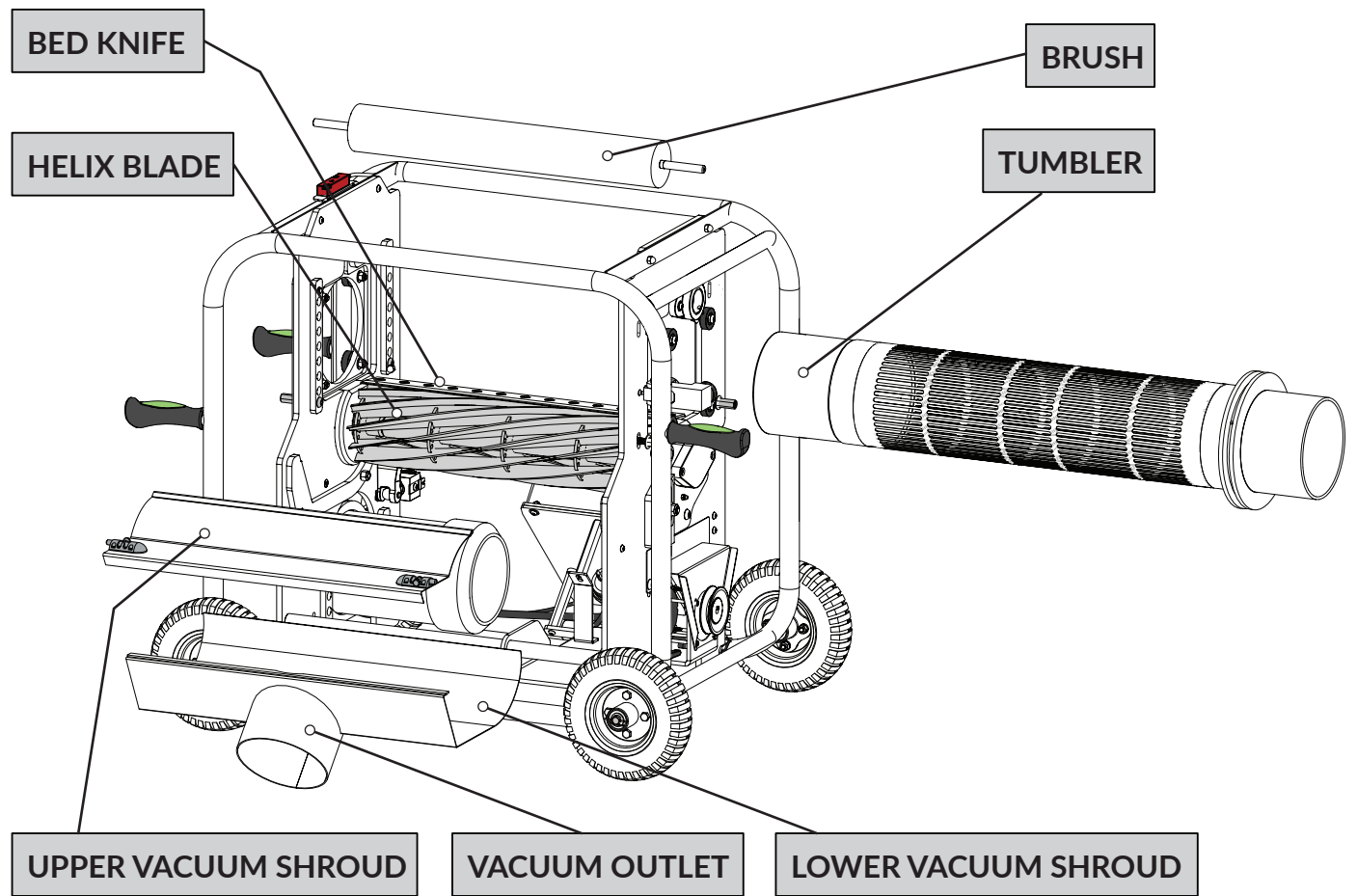

Fig. 2

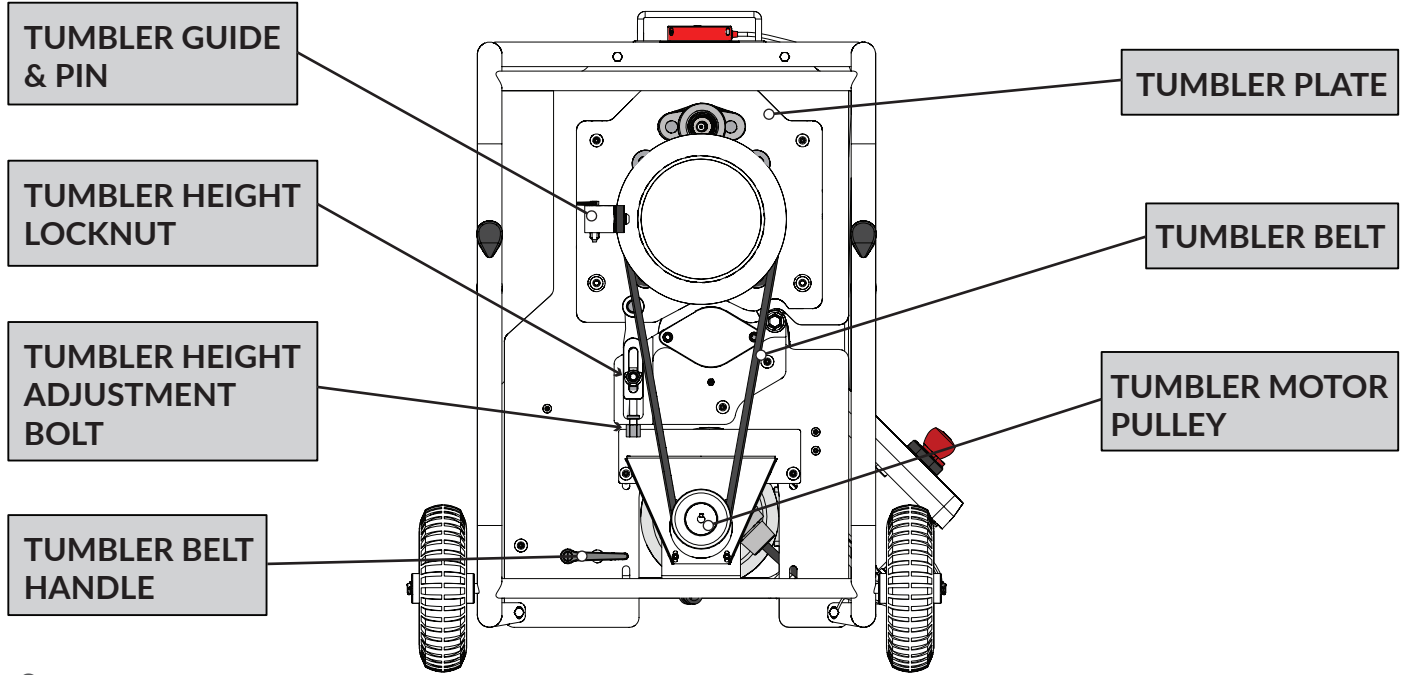

Fig. 3

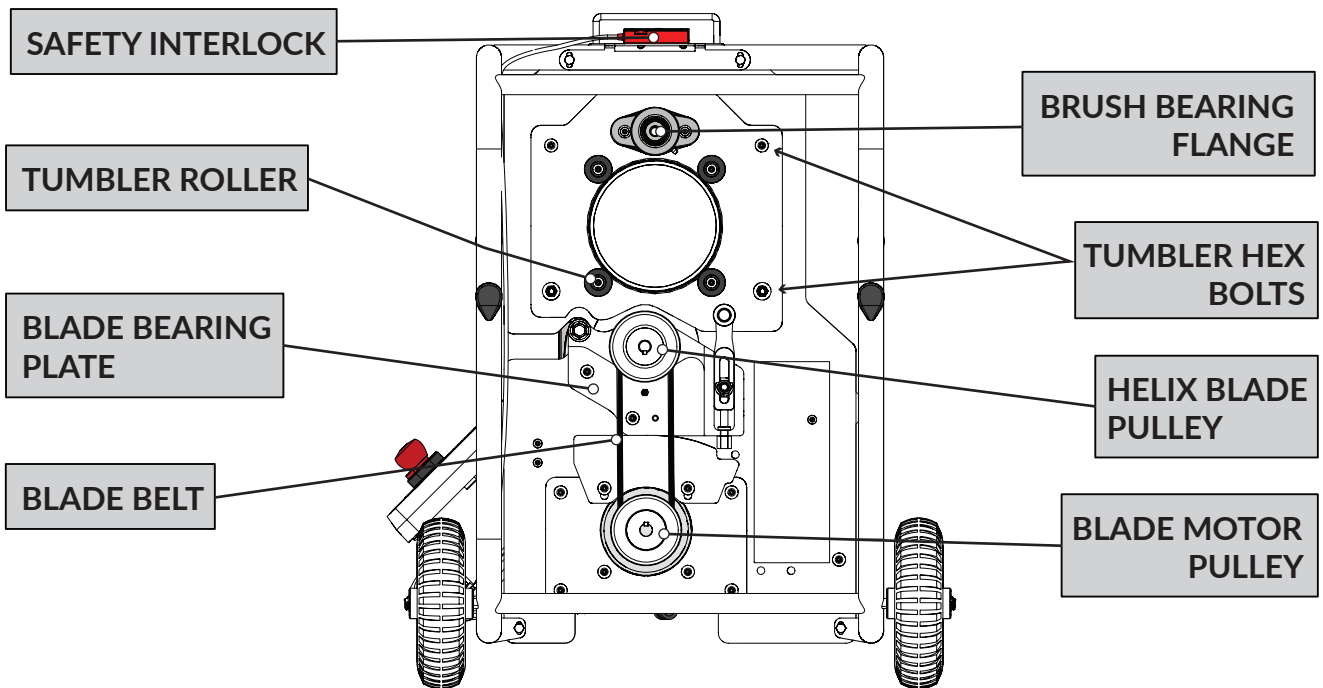
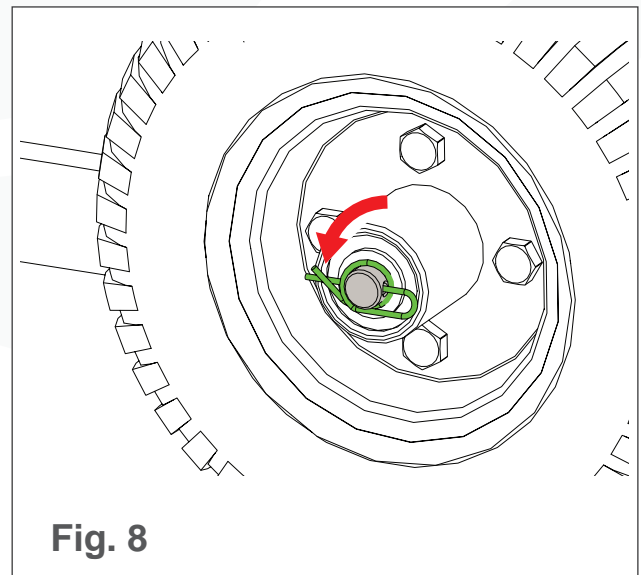
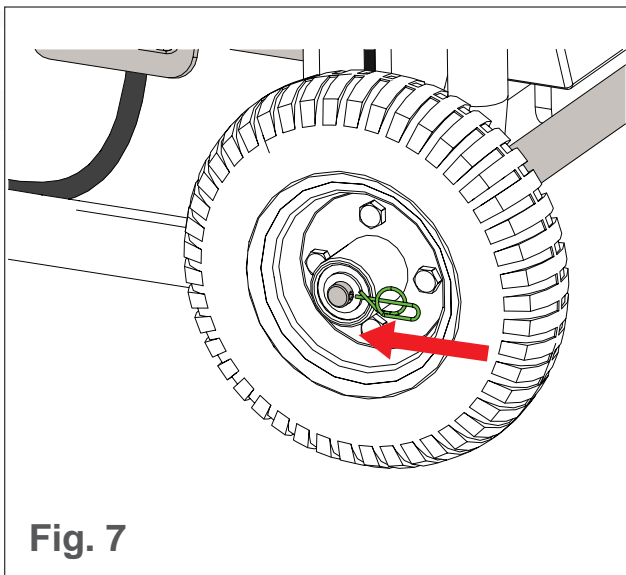
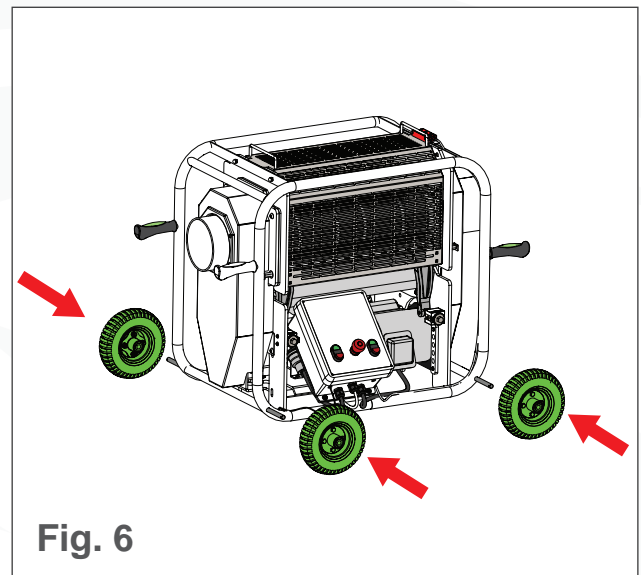
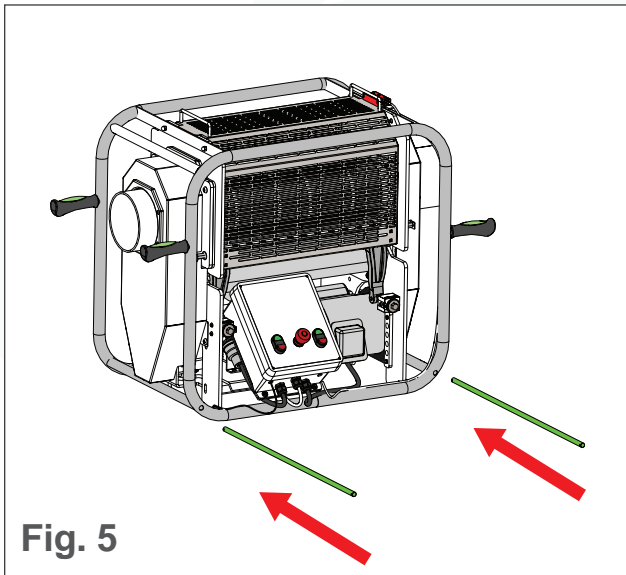

Fig. 4

Step 1: Attach Wheels

1. Slide the axles into the T2 frame (see Fig. 5).
2. Slide the wheels onto the axles (see Fig. 6).
3. Insert the cotter pins into the holes at the end of the axles (see Fig. 7).
4. Flip the cotter pin loop around the axle to secure wheels in place (see Fig. 8).



Step 2: Secure Placement

To most safely operate the T2, the machine should be placed on Twister Rails. For a list of available rails, see **Accessories** on page 52.

1. Set up the T2 rails where the machine will operate* (see **Recommended Placement**).
2. Place the T2 on rails and adjust the tilt (for instructions, see **Tilt Guidelines** and the corresponding Twister Rails manual).
3. If using multiple T2s in tandem**, place them end-to-end in a line (for instructions, see the corresponding Twister Rails manual).

**If the T2 is not being placed on Twister Rails, set up the T2 to operate on level ground.*

***Using multiple T2s in tandem (tumblers end to end) is more efficient than using them in parallel.*



WARNING

IF NOT USING RAILS, THE T2 MUST BE PLACED ON LEVEL GROUND. THE MACHINE WILL ROLL IF PLACED ON SLOPE, POSSIBLY CAUSING BODILY HARM AND DAMAGE TO THE MACHINE.

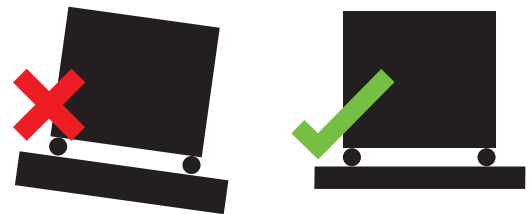

RECOMMENDED PLACEMENT

For best and safest operation, place the T2:

- On level ground
- Near an outlet
- In a cool environment*
- With enough space to easily access the tumbler inlet and outlet.

**It is highly recommended to operate the T2 in as cold of an environment as possible. Operating the T2 in colder environments will improve the machine's performance and significantly reduce build up on the machine.*

TILT GUIDELINES

Increasing the incline of the T2 will decrease the fill level of the tumbler and increase throughput. For optimal performance, the T2 should be 1/3 full of product at all times during operation. When starting a new product, it is normal to adjust the incline multiple times to optimize product throughput.

Step 3: Connect to Vacuum

For a list of available Twister Vacuums, see **Accessories** on page 53.

1. Set up either the Trim Saver or the Leaf Collector vacuums for operation (for instruction, see the respective vacuum manual).
2. Attach a hose to the vacuum outlet on the T2 and the vacuum inlet on the Trim Saver or the Leaf Collector (see Fig. 9. Trim Saver pictured).
3. Screw down the hose clamps.

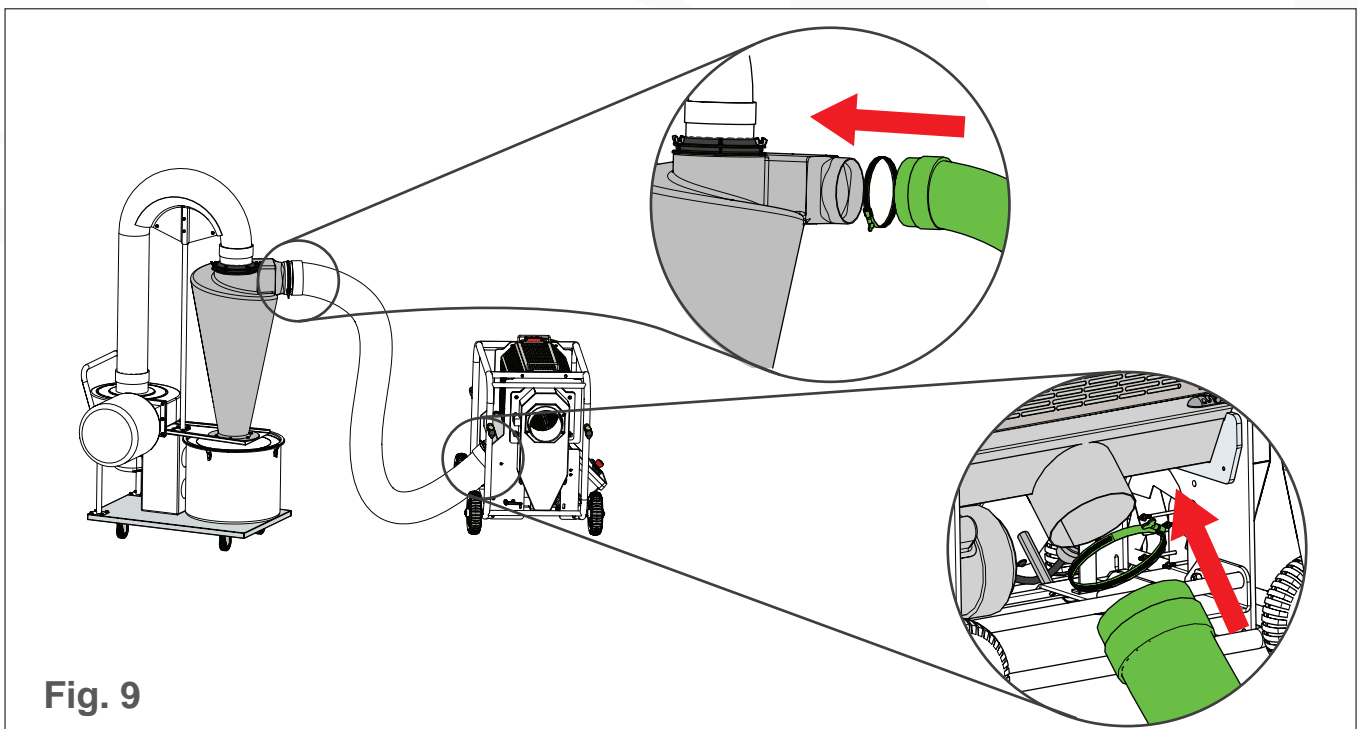

Fig. 9

Step 4: Align Conveyors/Attach Hopper

To safely feed product into the T2 tumbler, Twister Conveyors or a T2 Hopper is required (for a list of available conveyors and the Twister Hopper, see **Accessories** on page 52).

If Using Conveyors:

1. Set up the conveyors for operation (for instruction, see the corresponding conveyor manual).
2. Place the QC Conveyor under the T2 outlet* (see Fig. 10).
3. Place the Feed Conveyor inside the tumbler **without the conveyor touching the tumbler**** (see Fig. 11).

*If multiple T2s are connected, place the QC Conveyor under the last machine's outlet.

**If multiple T2s are connected, place the Feed Conveyor inside the first machine's tumbler.



CAUTION

TO AVOID POSSIBLE DAMAGE TO THE TUMBLER, ENSURE THE TUMBLER AND CONVEYOR ARE NOT IN CONTACT DURING OPERATION.

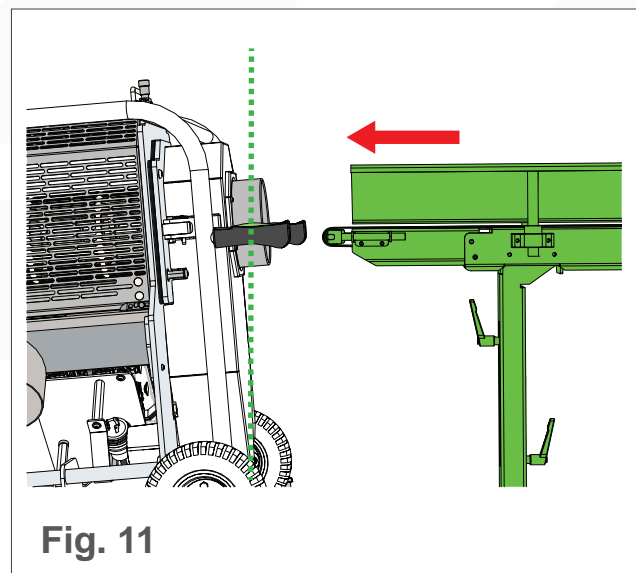
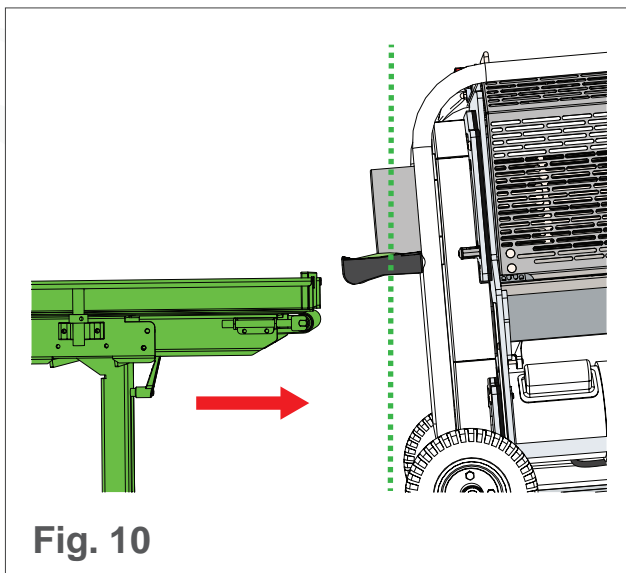

If Using the Hopper:

1. Remove the hopper bolts from one side of the T2 (see Fig. 12).
2. Secure the hopper mount bracket to the raised side of the T2 with screws and washers (see Fig. 13):
 - Use a 1" screw if attaching the hopper to the side of the T2 with the Safety Interlock.
 - Use a 7/8" screw if attaching the hopper to the side of the T2 without the Safety Interlock.

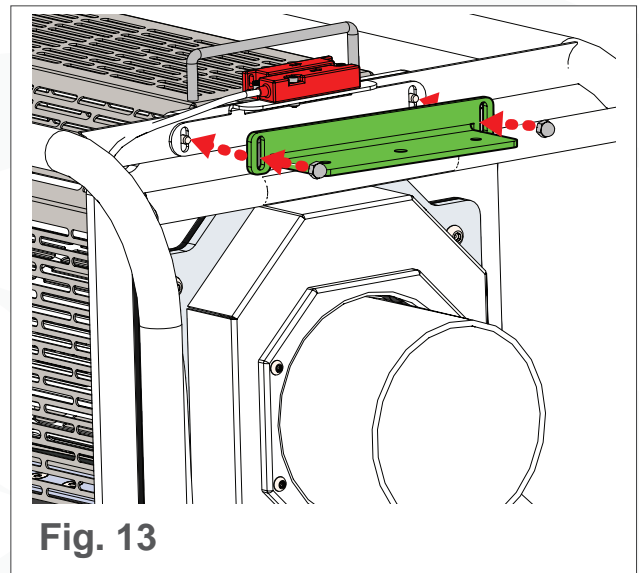
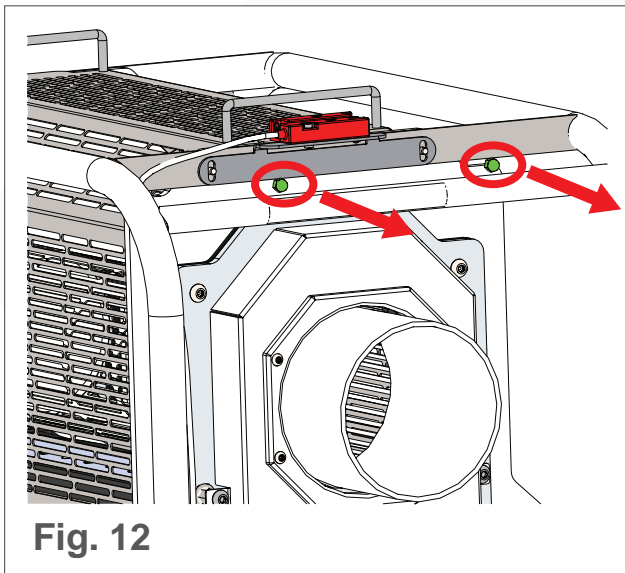

3. Secure the rest of the hopper to the hopper mount bracket with bolts and the hopper twist knob (see Fig. 14).
4. Place a container beneath the T2 outlet to collect product.

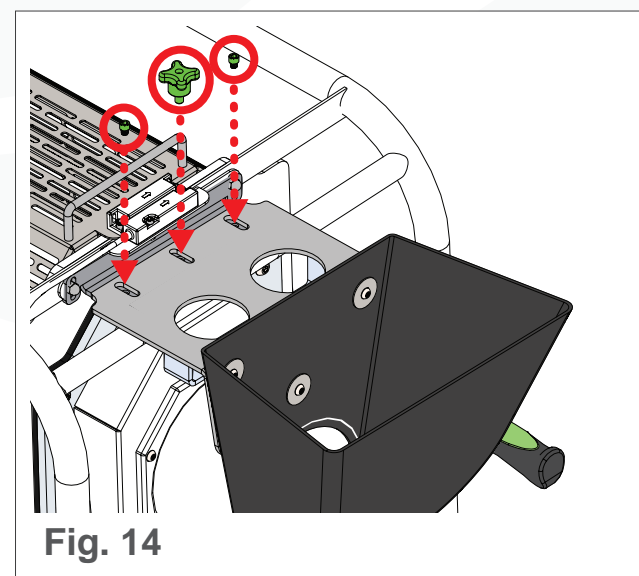

CONTROL BOX OVERVIEW

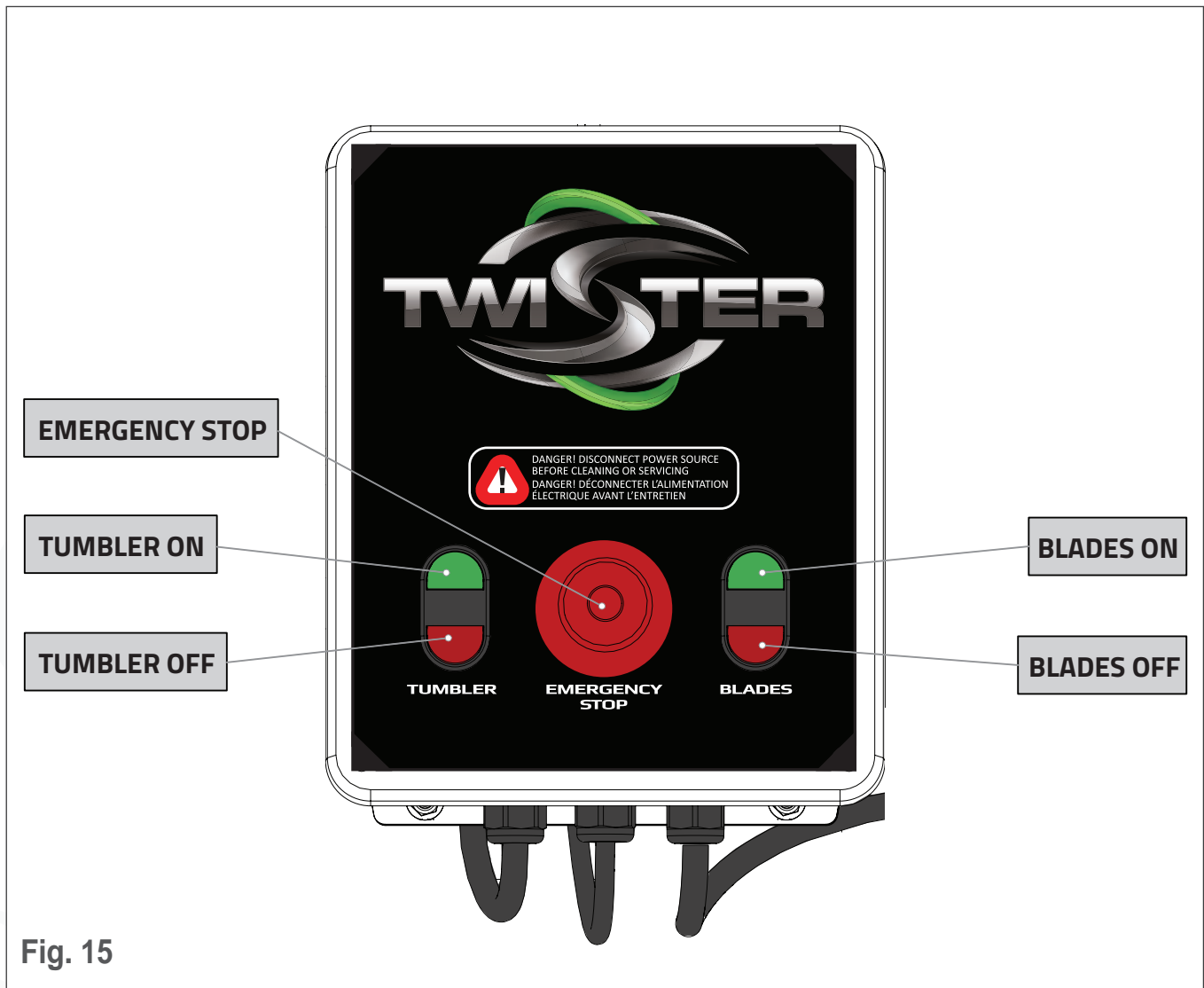

Fig. 15

Step 1: Pre-Operation Checks

The following checks should be completed before each use of the T2. Before operating, ensure:

1. The following are installed:
 - a. Belt covers
 - b. Tumbler guard
 - c. Vacuum shrouds
 - d. Vacuum hose.
2. The vacuum hose clamp is tight.
3. If using conveyors: the conveyors are aligned and clear of the spinning tumbler.



DANGER

DO NOT OPERATE THE T2 UNLESS THE MACHINE IS FULLY ASSEMBLED AND ALL PRE-OPERATION CHECKS ARE MADE.

Step 2: Power On

1. Connect the T2 to the extension cord (minimum 12AWG. See connector plug and extension cord specifications on pages 50-51).
2. Plug the extension cord into a socket.



CAUTION

THE EXTENSION CORD MUST BE RATED 12AWG MINIMUM. USING AN INAPPROPRIATE EXTENSION CORD WILL CAUSE LOSS OF POWER AND OVERHEATING.

Step 3: Start the Vacuum, Blades, and Tumbler

1. Turn on the vacuum.
2. Allow the vacuum to reach full speed.
3. Press the blades-on button to start the blade motor.
4. Allow the blades to reach full speed.
5. Press the tumbler-on button to start the tumbler motor.

Step 4: Feed the T2

1. Begin feeding product using either the conveyors or the T2 Hopper (see **Running Guidelines**).

Step 5: Power Off and Clean

1. Press the tumbler-off button to turn off the tumbler.
2. Press the blades-off button to turn off the blades.
3. Turn off the vacuum.
4. Unplug the T2 from power.
5. Detach the vacuum from the T2.
6. Clean the T2 (for cleaning instructions, see **Cleaning** on page 27).



DANGER

DO NOT PLACE HAND IN THE TUMBLER DURING OPERATION!

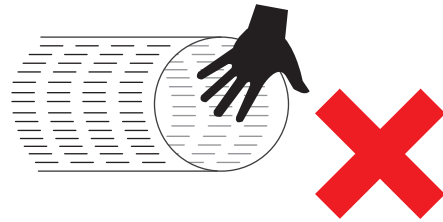

CAUTION

THE T2 MUST BE CLEANED AFTER EACH USE. IF NOT, RESIDUE WILL HARDEN, CAUSING REDUCED PERFORMANCE AND EXTREMELY DIFFICULT CLEANING.

RUNNING GUIDELINES

- Have 1-4 quality control personnel observing product exiting the T2 outlet.
- Feed the machine consistently. Inconsistent feeding will result in inconsistent trimming.
 - If using a hopper, feed the T2 with consistent handfuls at consistent intervals.
 - If using conveyors, fill the Feed Conveyor to a consistent height.
- Adjust feeding speed to have the same volume of product exiting and entering the machine simultaneously.
- Adjust the T2 to operate with the tumbler 1/3 full (see **Tilt Guidelines** on page 10).
- If wet trimming, spray the brush every 5 minutes with cold distilled water to reduce buildup on the tumbler (if dry trimming, there is no need to spray the brush).
- If dry trimming, use a Vacuum Bypass (product number: 23-0255) to reduce suction and prevent the T2 holding too much product.

The T2 needs to be disassembled to conduct routine cleaning, maintenance, and any repairs. Conduct the following steps in order to disassemble the T2:

Step 1: Remove the Tumbler Guard

1. Ensure the T2 is unplugged.
2. Lift the tumbler guard up and off the machine (see Fig. 16).

Step 2: Remove the Belt Covers

1. Remove the two tumbler belt cover screws (see Fig. 17).
2. Remove the tumbler belt cover.
3. Repeat steps 1 and 2 on the blade belt cover.

Step 3: Remove the Tumbler Belt and Tumbler

1. Remove the tumbler guide pin (see Fig. 18).

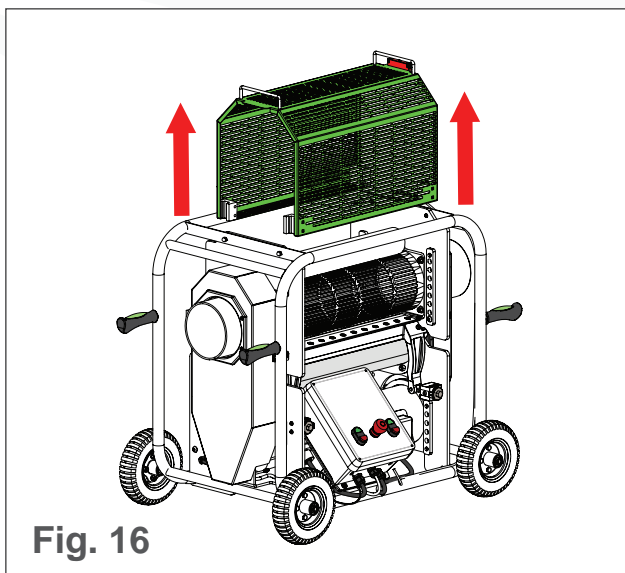

Fig. 16

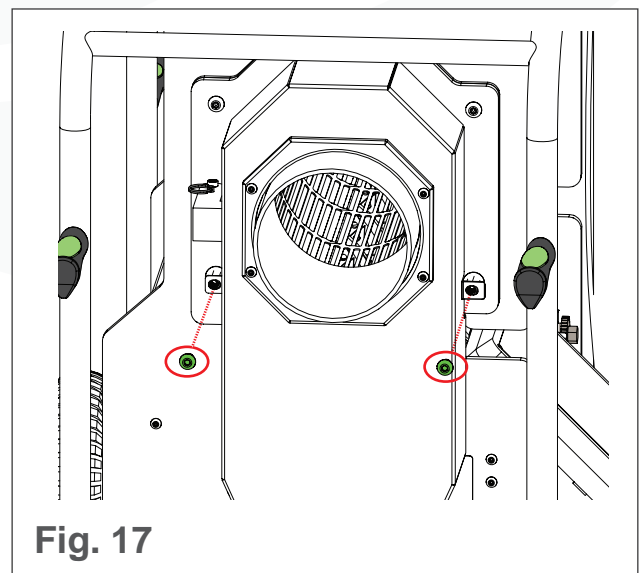

Fig. 17

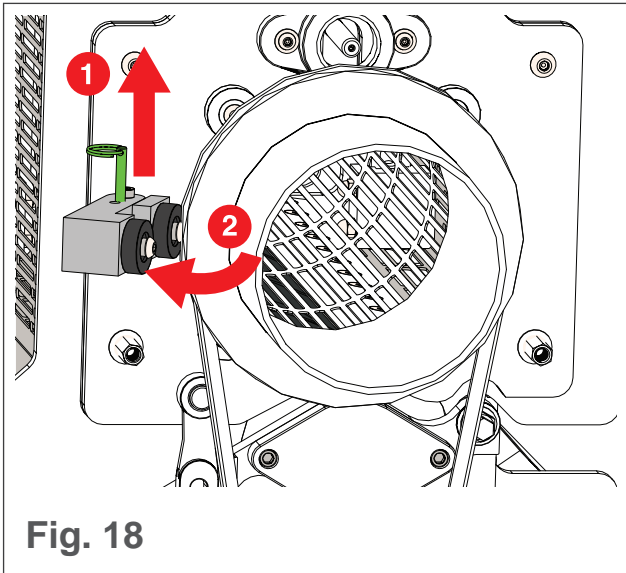

Fig. 18

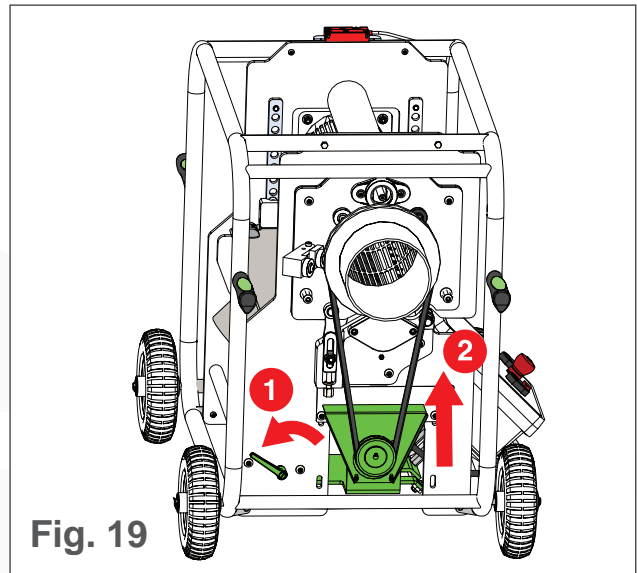

Fig. 19

2. Rotate the tumbler guide out (see Fig. 18).
3. Rotate the tumbler belt handle (see Fig. 19).
4. Lift the tumbler motor pulley (see Fig. 19).
5. Remove the tumbler belt (see Fig. 20).
6. Remove the tumbler (see Fig. 21).

CAUTION

THE TUMBLER IS FRAGILE. REMOVE CAREFULLY. HANDLE THE TUMBLER BY ITS END CAPS AND AVOID THE TUMBLER CONTACTING THE BLADES.

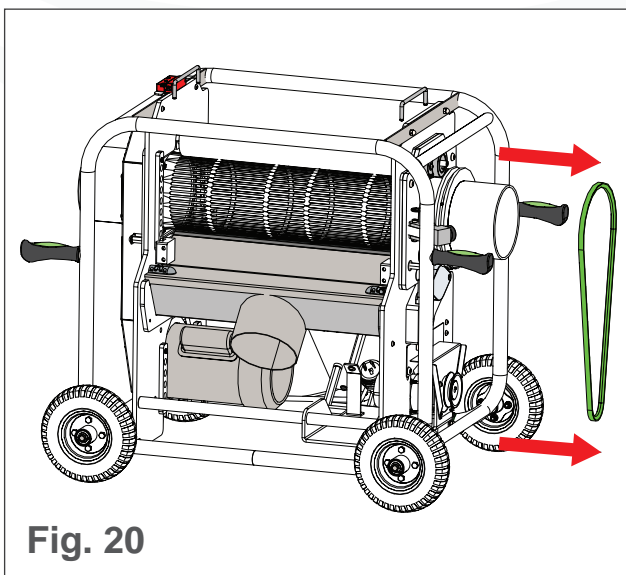

Fig. 20

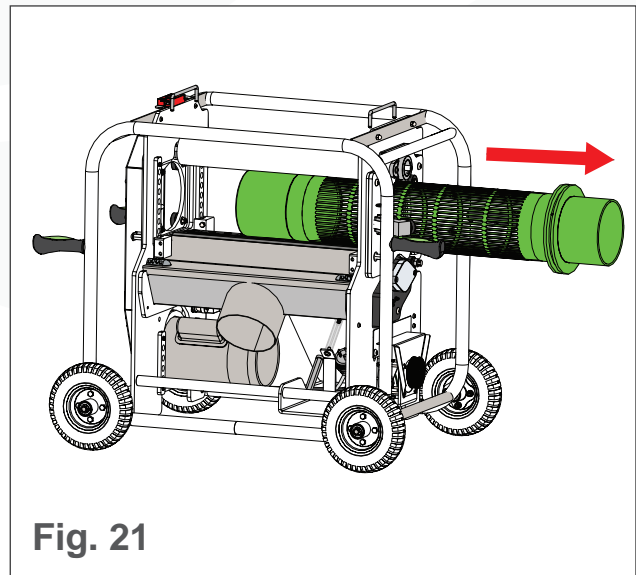
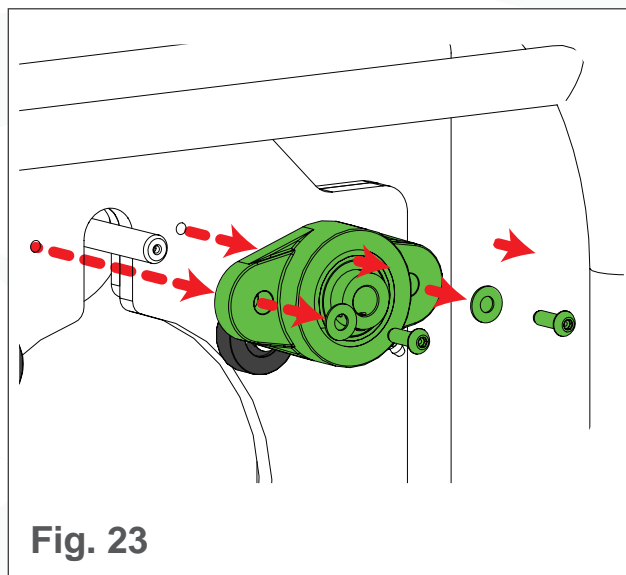
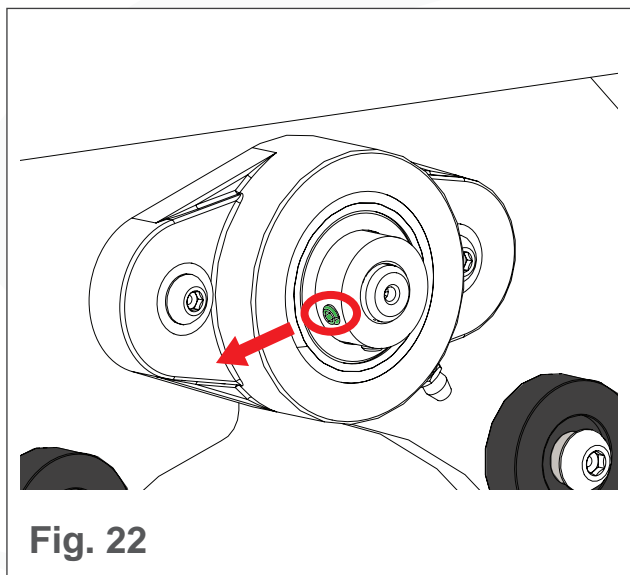

Fig. 21

Step 4: Remove the Brush

1. Remove the set screws on both brush bearing flanges (See Fig. 22).
2. Remove the bolts and washers on the brush bearing flange located on the tumbler belt side of the machine (see Fig. 23).
3. Remove the brush bearing flange on the tumbler belt side of the machine (see Fig. 23).
4. Remove the brush (see Fig. 24).



Step 5: Remove the Vacuum Shrouds

1. Ensure the suction hose is not connected to the vacuum outlet.
2. Slide the upper vacuum shroud latches inward (see Fig. 24).
3. Pull the upper vacuum shroud straight out (see Fig. 25).

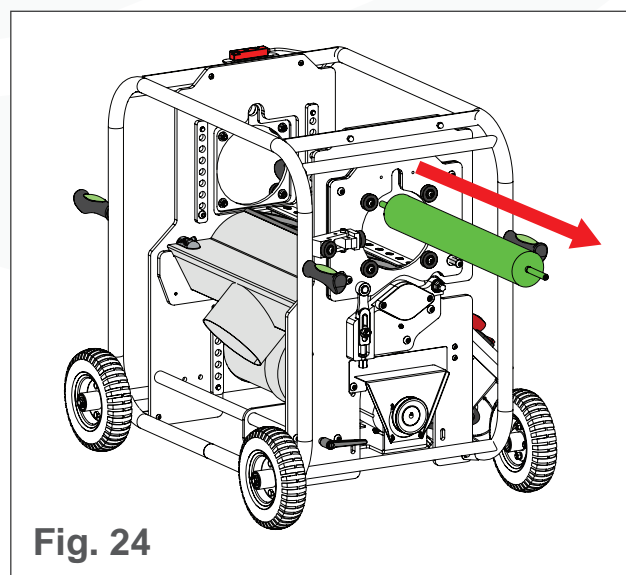

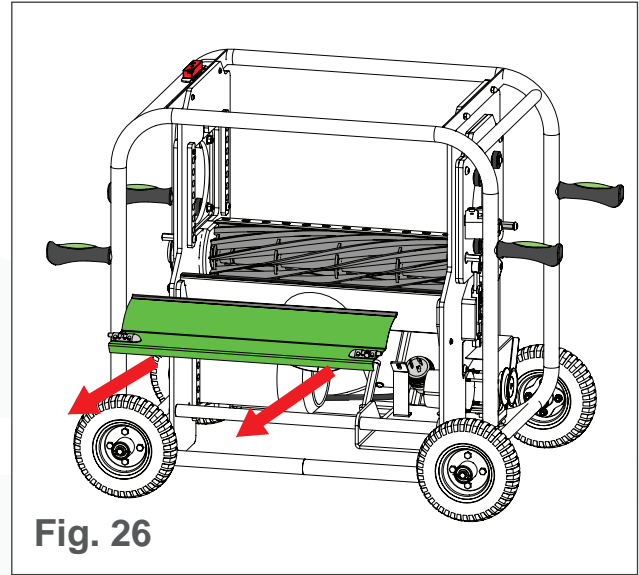
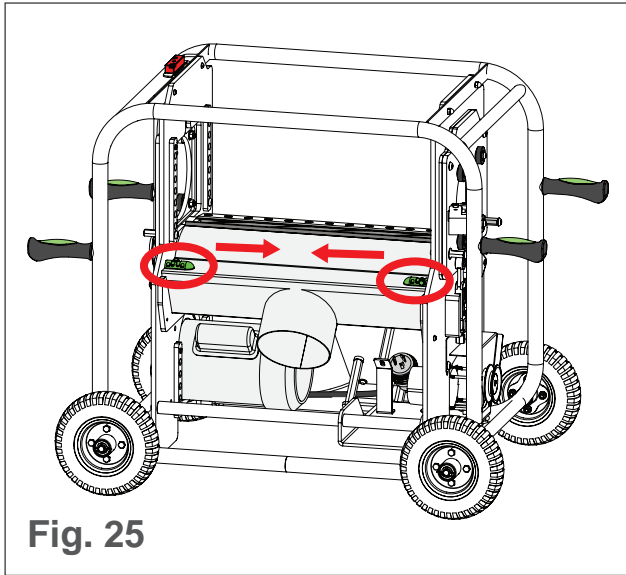

4. Rotate the lower vacuum shroud up 1/4 turn to clear the blade (see Fig. 27).
5. Carefully pull out the lower vacuum shroud at a slight angle (see Fig. 28).

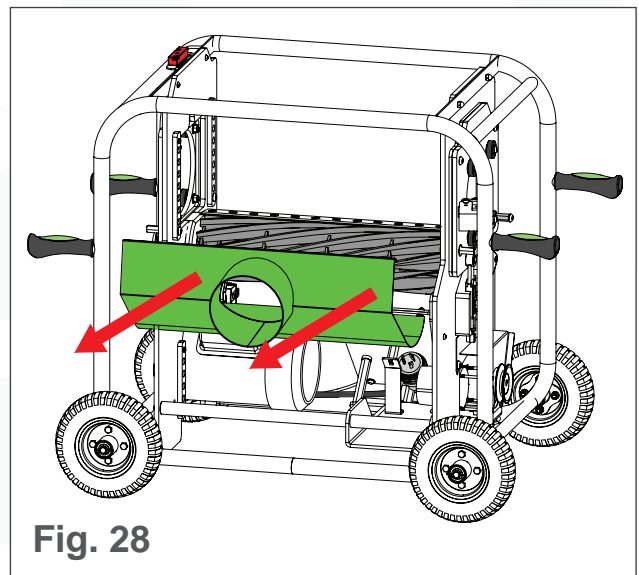
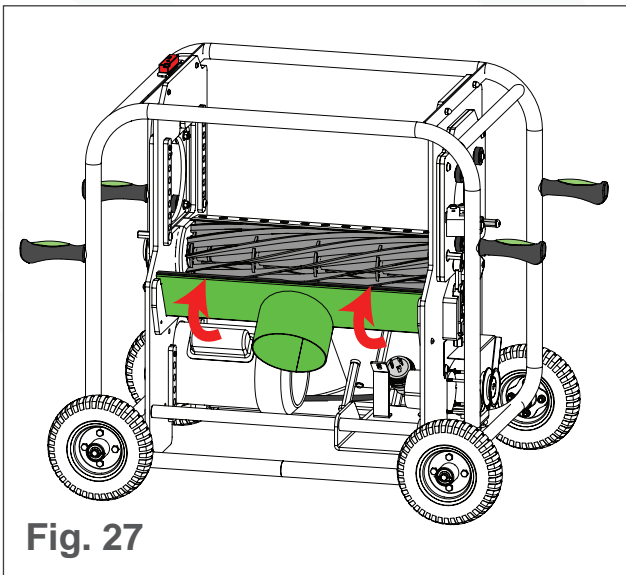

Step 1: Install the Vacuum Shrouds

1. Ensure the T2 is unplugged.
2. Carefully place the lower vacuum shroud above its operating position at a slight angle (see Fig. 29).
3. Rotate the lower vacuum shroud 1/4 turn down to the clear blades, and slot into place (see Fig. 30).
4. Directly insert upper vacuum shroud (see Fig. 31).
5. Slide upper vacuum shroud latches inward, place shroud in operating position, and release latches (see Fig. 32).

Step 2: Install the Brush

1. Insert the brush, and hold in place (see Fig. 33).



DANGER

THE T2 MUST BE UNPLUGGED
DURING REASSEMBLY.

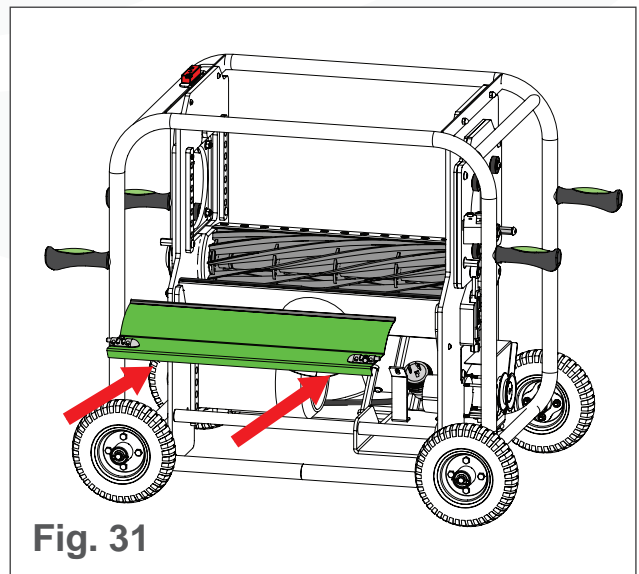
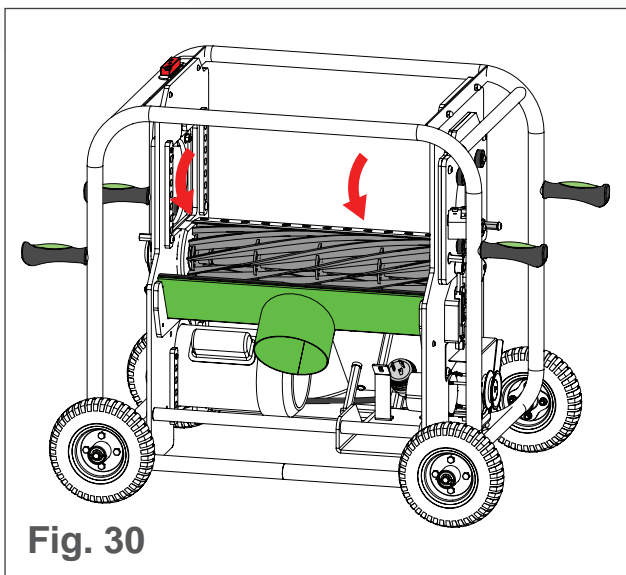
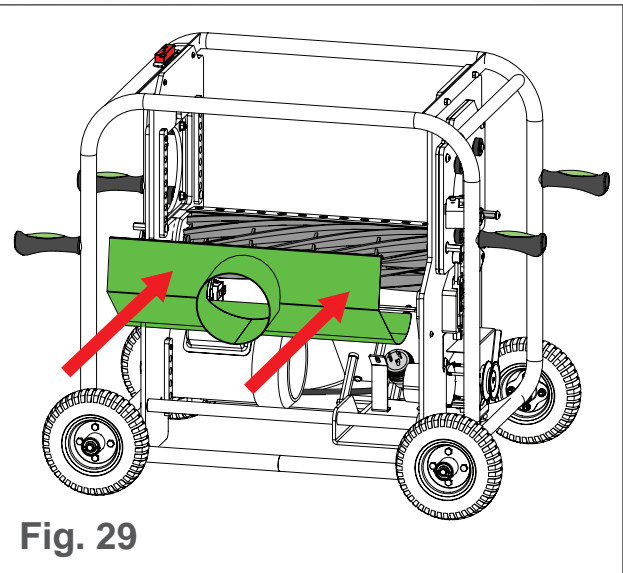
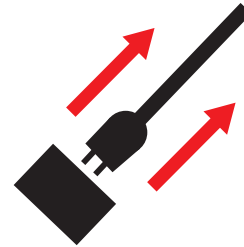

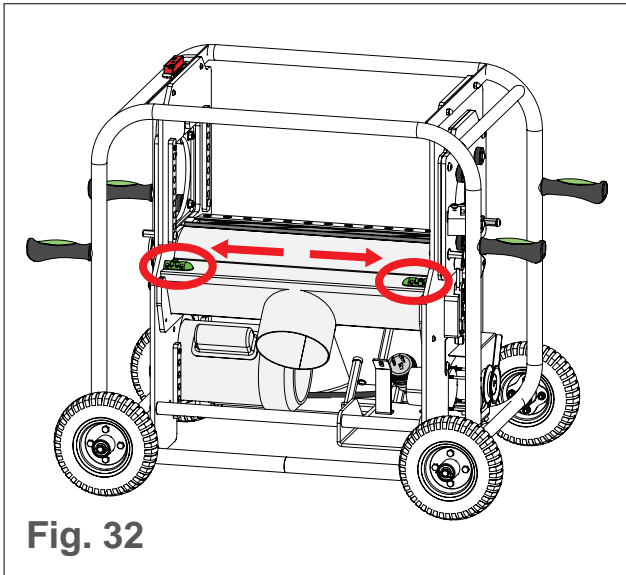

Fig. 32

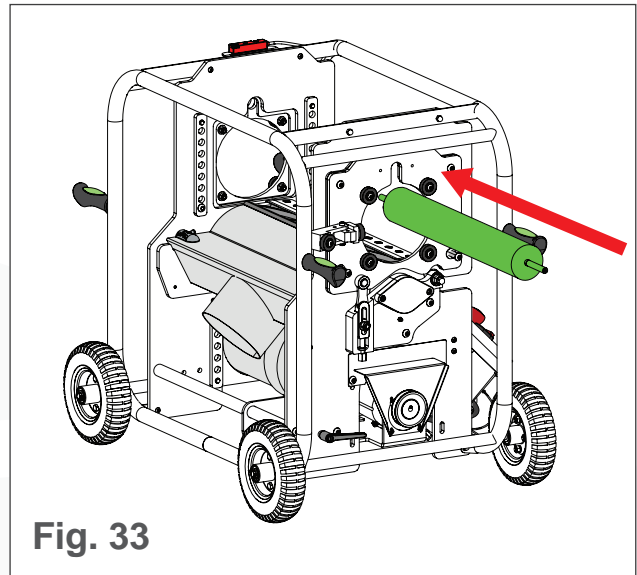

Fig. 33

2. Place the brush bearing flange on the end of the brush (see Fig. 34).
3. Secure the brush bearing flange by inserting the bolts and washers (see Fig. 34).
4. Insert and tighten the set screws on both brush bearing flanges (see Fig. 35).

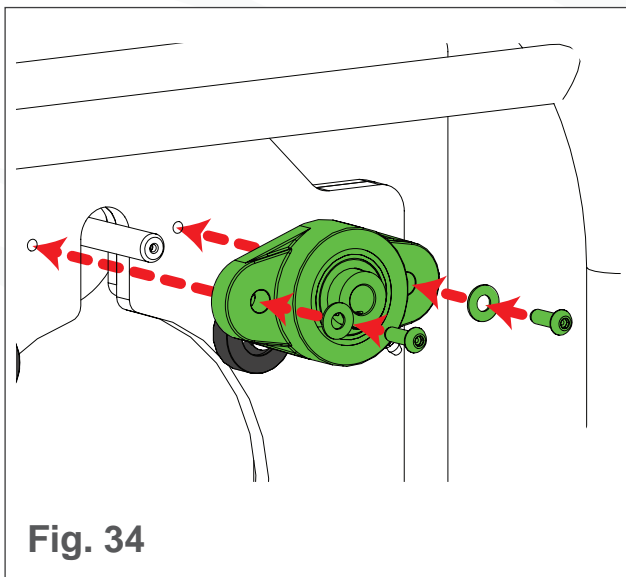

Fig. 34

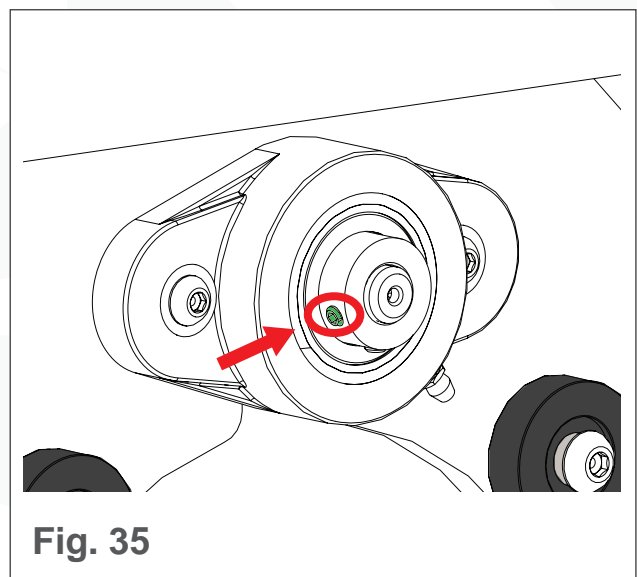
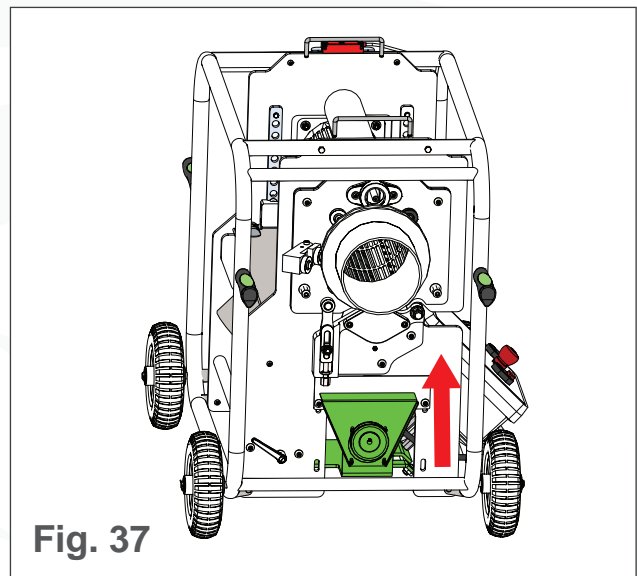
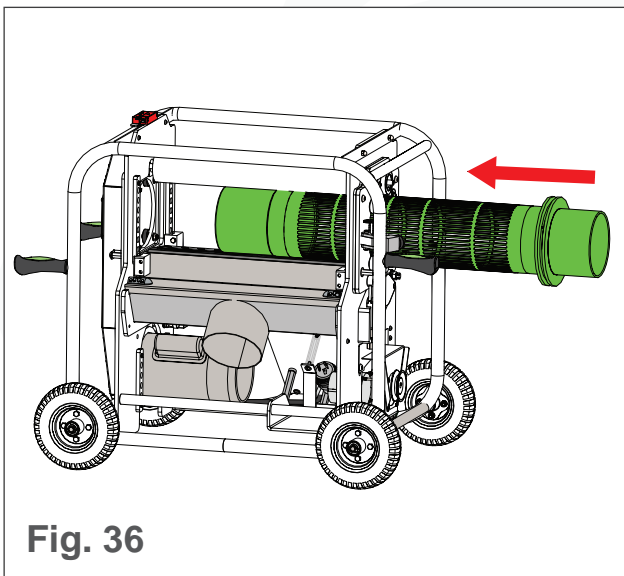

Fig. 35

Step 3: Install the Tumbler and Tumbler Belt

1. Insert the tumbler (see Fig. 36).
2. Lift the tumbler motor pulley (see Fig. 37).
3. Install the tumbler belt.
4. Allow the tumbler motor to drop. The weight of the motor will provide the necessary tension for the tumbler belt.



5. Rotate the tumbler belt handle back (see Fig. 38).
6. Rotate the tumbler guide back to its lock position (see Fig. 39).
7. Insert the tumbler guide pin (see Fig. 39).

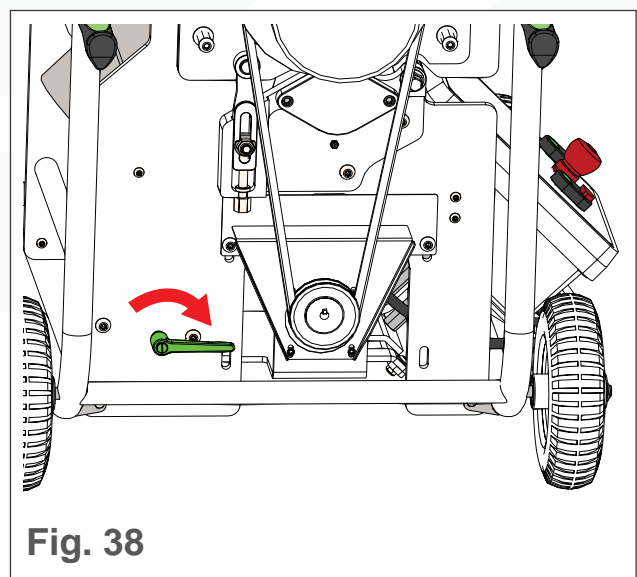

Step 4: Install the Belt Covers

1. Place the tumbler belt cover over the tumbler belt (see Fig. 40).
2. Insert and tighten the tumbler belt cover screws (see Fig. 40).
3. Repeat steps 1 and 2 on the blade belt cover.

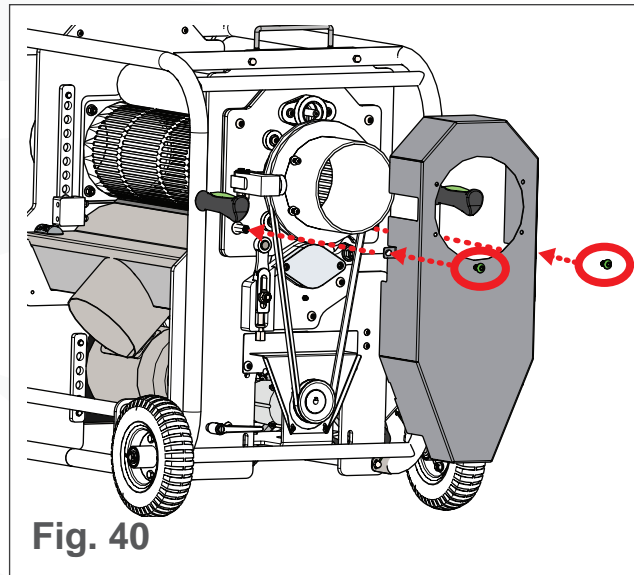
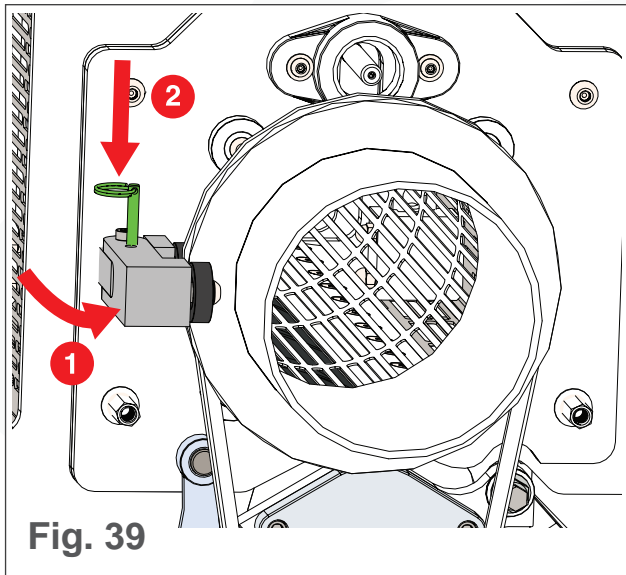

Step 5: Install the Tumbler Guard

1. Lower the tumbler guard onto the machine (see Fig. 41).

Step 6: Connect the Vacuum

1. Connect the hose to the vacuum outlet on the T2.
2. Connect the hose to the vacuum inlet on the Trim Saver or Leaf Collector vacuum.

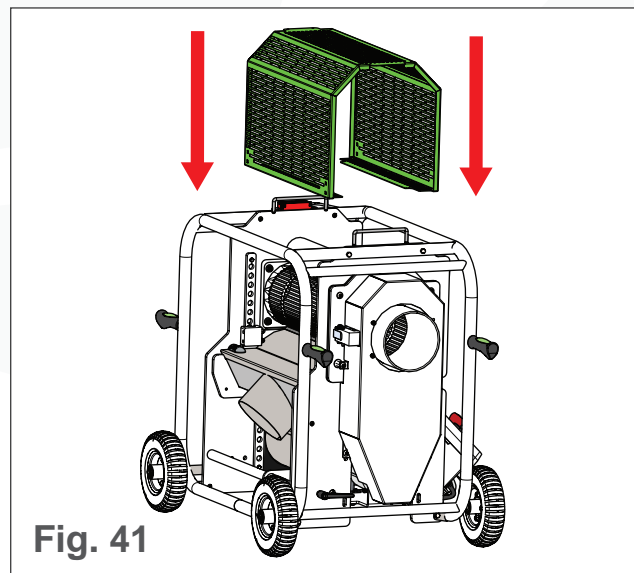

To ensure optimal performance, **ALL** of the following inspections should be made on the T2 on a weekly basis. **Ensure the T2 is unplugged before conducting any inspections.**

Inspect the Vacuum Shrouds

1. With the shrouds installed, inspect their edges to ensure there are no major gaps between the shrouds and the blade cartridge.
2. Ensure all the shrouds are tight.
3. Inspect for any visible damage.
4. Ensure all the edge gaskets are seated properly.
5. Inspect the hose for any wear, tear, or cracking.
6. Ensure the hose cuffs are on tight and free of damage.

Inspect the Brush

1. Inspect the bristles for any damage or flat spots.
2. Ensure the brush protrudes at least 1/8" through the tumbler slots.
3. Ensure the brush rotates when the tumbler is rotating.
4. Ensure the bearings roll smoothly.
5. Ensure the brush bearing flange set screws are tight on the brush.

Inspect the Tumbler

1. Check for any gouges, obvious scrapes, or visible damage.



DANGER

TURN OFF ALL MOTORS, THEN UNPLUG THE T2 BEFORE CONDUCTING INSPECTIONS.

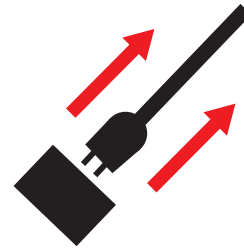

CAUTION

ANY GAPS AROUND THE VACUUM SHROUDS WILL DECREASE VACUUM SUCTION.

2. While the room is quiet, rotate the tumbler and listen for any contact with the blades. A “ting” sound means the tumbler is contacting the blades (if a “ting” sound is heard, the tumbler needs adjusting; see **Tumbler Adjustments** on page 33).
3. Ensure the tumbler pulley is on tight.
4. Ensure the set screws on the widest part of the tumbler are inside the grooves (see Fig. 42).

Inspect the Tumbler Belt

1. Inspect the belt for any fraying, kinks, or any other damage.
2. Check the belt tension. Ensure the tumbler spins when the belt is pulled.
3. Inspect all the pulleys, ensuring the bearings spin smoothly and the bolts are tight.

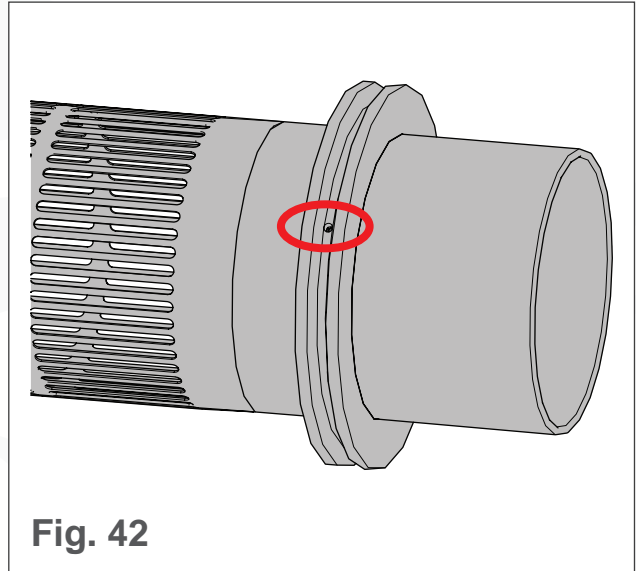

Fig. 42

Inspect the Blades

1. Inspect the blades for any damage to the blade edges.
2. Spin the blades by hand, ensuring a smooth rotation with light contact.
3. Perform a leaf cut test* (see **Adjusting the Blade**, step 8, on page 31).

*Only perform a leaf cut test prior to the T2 being sanitized.

⚠ WARNING

**CUTTING HAZARD!
THE BLADES ARE SHARP.
BE CAREFUL WHEN HANDLING
THE BLADES.**

Inspect the Blade Belt

1. Check the belt tension. Ensure the blade spins when the belt is pulled.
2. Inspect the belt for any fraying, kinks, loose links, or any other damage.
3. Inspect all the pulleys, ensuring the bearings spin smoothly and the bolts are tight.

Inspect the Tumbler Rollers

1. Check all contact surfaces for wear, cracks, or any other damage.
2. Rotate each roller by hand. The roller bearings should spin smoothly without wobbling.
3. Ensure all the roller bolts are tight. If loose, torque the roller bolts to 11 ft-lbs.

Inspect the Wheels

1. Ensure all the cotter pins are in place.
2. Ensure the wheel bearings roll smoothly.
3. Inspect the wheels for flat spots.

Inspect the Control Box

1. Ensure all the buttons are tightly placed.
2. Ensure all the exiting cables are tight in the cord grips.

To ensure optimal performance, the following cleaning steps should be completed between each use of the T2.

1. Disassemble the machine (for instructions, see **Disassembly** on page 16).
2. Soak the tumbler, vacuum hoses, and tumbler brush in hot water and mild detergent.
3. Coat the rest of the T2 in a foaming detergent.
4. Allow the detergent to sit for five minutes.
5. Repeat steps 3 and 4 two-three times.
6. Pressure wash all the components* to remove residue (use a plastic scraper to remove any difficult to clean areas).
7. Dry all the components with compressed air.
8. Spray all the component surfaces with 70% isopropyl alcohol to sanitize.
9. Allow the alcohol to evaporate.
10. Reassemble the machine (for instructions, see **Reassembly** on page 20).

**Except for the brush, and avoid any direct water contact with the control panel, both motors, and blade bearing covers (located at the two points where the helix blade is secured to rest of machine). These parts can become wet but may damage if they are directly pressure washed.*



DANGER

TURN OFF ALL MOTORS, THEN UNPLUG THE T2 BEFORE CONDUCTING ANY MAINTENANCE.

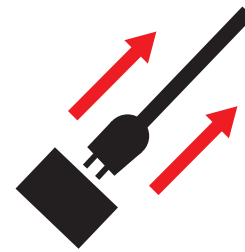

CAUTION

DO NOT POWER WASH THE TUMBLER BRUSH, CONTROL PANEL, MOTORS OR BLADE BEARING COVERS.



CAUTION

PRESSURE WASH THE TUMBLER FROM A DISTANCE OF 6" AWAY TO PREVENT DAMAGE.

Greasing

To increase the life of the blade bearings, the blade bearings must be greased every 1000 hours with food-grade grease. Only grease the blade bearings—the **brush bearings do NOT require greasing**. To grease the blade bearings:

1. Ensure the T2 is unplugged.
2. Remove both belt covers (see **Step 2: Remove the Belt Covers in Disassembly** on page 16 and Fig. 43).
3. Pump grease into the grease nipples (see Fig. 44):
 - If using a long-handled grease gun, pump 5-7 times.
 - If using a pistol grip grease gun, pump 7-15 times.



DANGER

TURN OFF ALL MOTORS THEN
UNPLUG THE T2 BEFORE
CONDUCTING ANY MAINTENANCE.

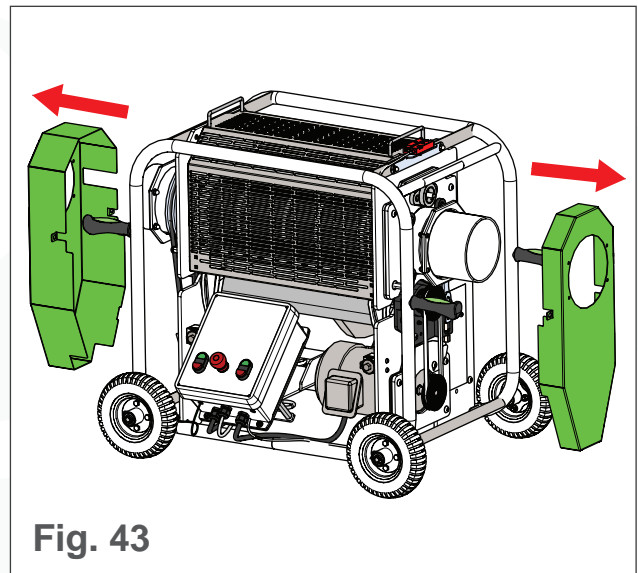
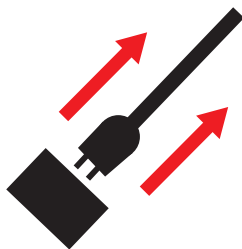

Fig. 43



CAUTION

DO NOT OVER GREASE.
OVER GREASING WILL PUSH OUT
THE BEARING SEALS.

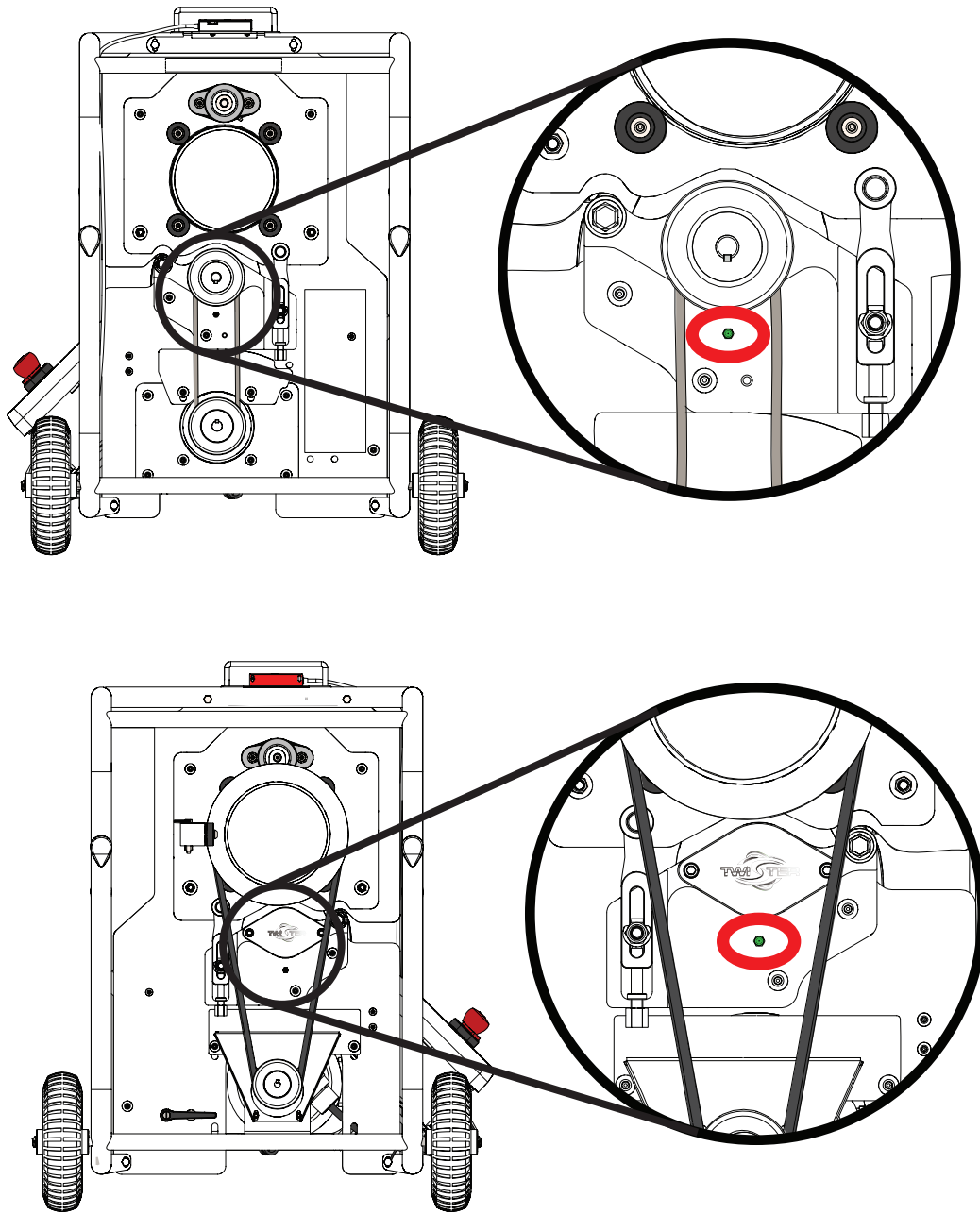

Fig. 44

Blade Adjustments

On a properly adjusted T2, the blades should have light contact with each other in a self-sharpening action, and a fast ticking sound should be present. Periodic adjustment of the blades will be required to ensure they are still in contact with each other.

Before Adjusting the Blade

1. Ensure the T2 is unplugged.
2. Remove the tumbler and protective covers.
3. Read **Blade Adjustment Tips**.



DANGER

**TURN OFF ALL MOTORS, THEN
UNPLUG THE T2 BEFORE
CONDUCTING ANY MAINTENANCE.**

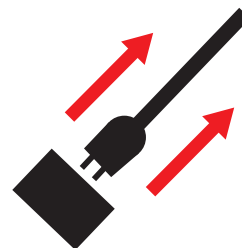

BLADE ADJUSTMENT TIPS

- Make adjustments using a 5/8" wrench.
- Adjustment clickers are located on the control panel side of the T2 (see Fig. 45).
- Adjustment clickers adjust the bed knife position against the helix blade.
- Each adjustment click corresponds to a 0.0007in/0.0018mm bed knife movement.
- Clockwise rotation decreases blade contact.
- Counter-clockwise rotation increases blade contact.
- Adjust clickers simultaneously when large adjustments are made.



CAUTION

**FOR LARGE BED KNIFE ADJUSTMENTS, ADJUST
CLICKERS SIMULTANEOUSLY TO PREVENT
BENDING THE BED BAR.**



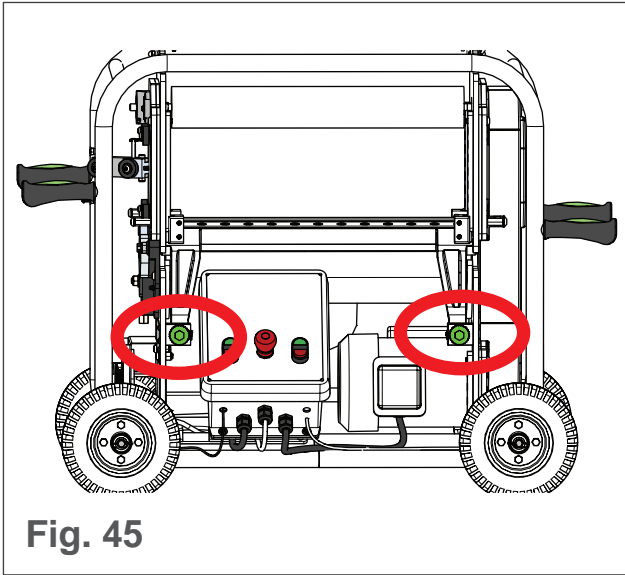

Fig. 45

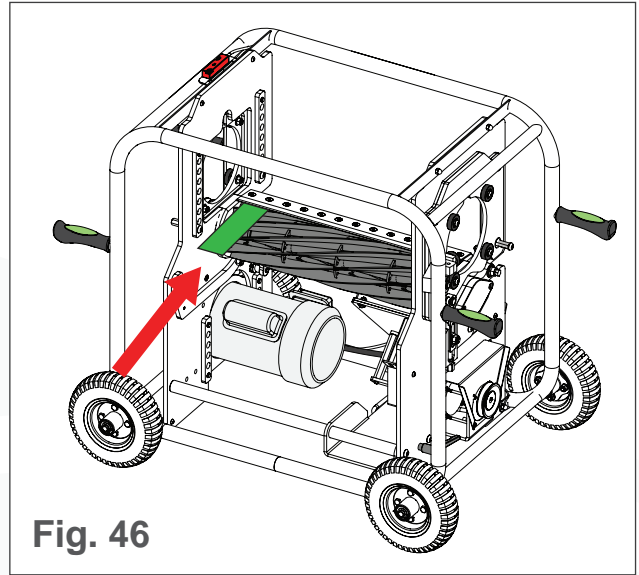

Fig. 46

Adjusting the Blade

1. Turn the adjustment clickers clockwise so there is no contact between the blades.
2. At one end of the blade, insert a 0.005" shim horizontally between the helix blade and the bed knife (see Fig. 46).
3. Slowly turn the adjustment clickers counter-clockwise to tighten the blade distance until there is a 0.005" gap between the helix blade and the bed knife. This will become apparent when there is slight friction holding the shim in place as you try to remove it.
4. Repeat steps 2 and 3 on other end of the blade ensuring the helix blade and bed knife are parallel.
5. Once the blades are parallel with a 0.005" gap, rotate the helix blade pulley to spin the helix blade. There should be no resistance between the blades.



WARNING

**CUTTING HAZARD!
THE BLADES ARE SHARP.
BE CAREFUL WHEN HANDLING
THE BLADES.**



6. Slowly turn the adjustment clickers counter-clockwise an additional 7 clicks*
There should now be light contact between the helix blade and bed knife.
7. Rotate the drive pulley to spin the helix blade. There should now be resistance to spinning the helix blade caused by friction between the helix blade and bed knife.
8. (Optional) Perform a leaf cut test to verify that the blade adjustments were done correctly and to ensure ideal trimming conditions**:
 - a. Insert a leaf at a right angle to the bed knife, and rotate the blades to cut the leaf (see Fig. 47).
 - b. Repeat step 8.a. at multiple places along the length of bed knife (see Fig. 47).
 - c. If the leaf does not cut cleanly, readjust the blades and perform steps 8.a. and 8.b. until it does.

**Due to backlash within the bedbar adjustment mechanism, it is possible that the machine will need up to 10 clicks to achieve the ideal blade contact and resulting friction. This may vary between machines in a tandem setup.*

***Only perform a leaf cut test prior to the T2 being sanitized.*

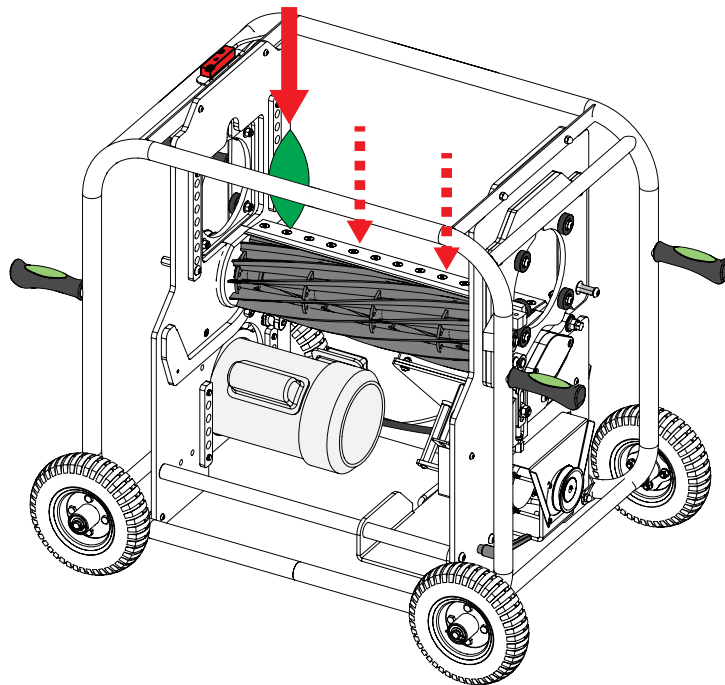

Fig. 47

Tumbler Adjustments

If the tumbler becomes damaged, adjustments can be made to avoid the damaged tumbler contacting the blades. However, **tumbler adjustments are a temporary measure until the tumbler can be replaced.** While the following adjustments allow continued trimming, they will result in decreased trim quality.

To make tumbler adjustments.

1. Ensure the T2 is unplugged.
2. Remove the tumbler belt (see **Disassembly** on page 16).
3. Loosen the hex bolts on both sides of the tumbler (see Fig. 48).
4. Loosen the tumbler height locknuts on both sides of the tumbler (see Fig. 49).



DANGER

TURN OFF ALL MOTORS, THEN
UNPLUG THE T2 BEFORE
CONDUCTING ANY MAINTENANCE.

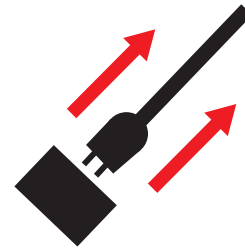

CAUTION

IF THE TUMBLER BECOMES
DAMAGED, REPLACE WITH A NEW
TUMBLER.

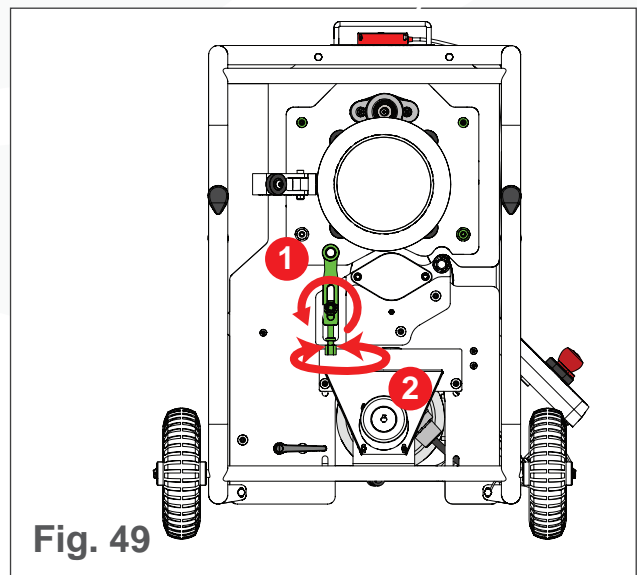
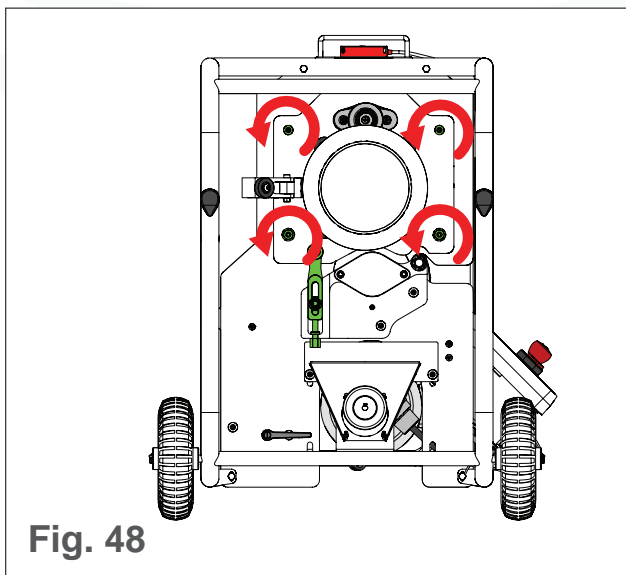

5. Turn the tumbler height adjustment bolts on both sides of the tumbler to raise or lower the tumbler (see Fig. 49):
 - Turn the adjustment bolt clockwise to lower.
 - Turn the adjustment bolt counter-clockwise to raise.
6. Spin the tumbler to ensure there is no contact with the blades.
7. Once both sides are adjusted and the tumbler has been spin tested, retighten the locknut then the hex bolts in reverse order on both sides of the tumbler.

Blade Belt Replacement

Over time, the blade belt will see natural wear. The blade belt should be replaced if it shows any signs of wear or physical damage. It is recommended to keep a spare blade belt for quick replacement. To replace the blade belt:

1. Ensure the T2 is unplugged
2. Flip the T2 on its handles with the motor plate facing up to make replacement easier (see Fig. 50).
3. Remove the belt cover screws (see Fig. 51).
4. Remove the belt cover.

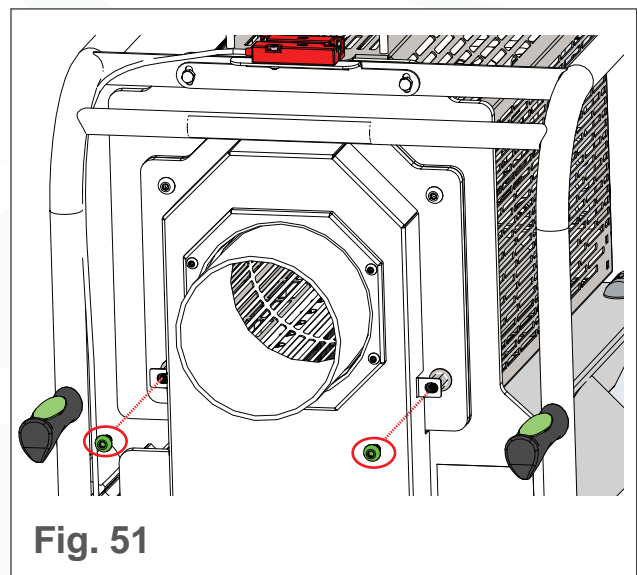
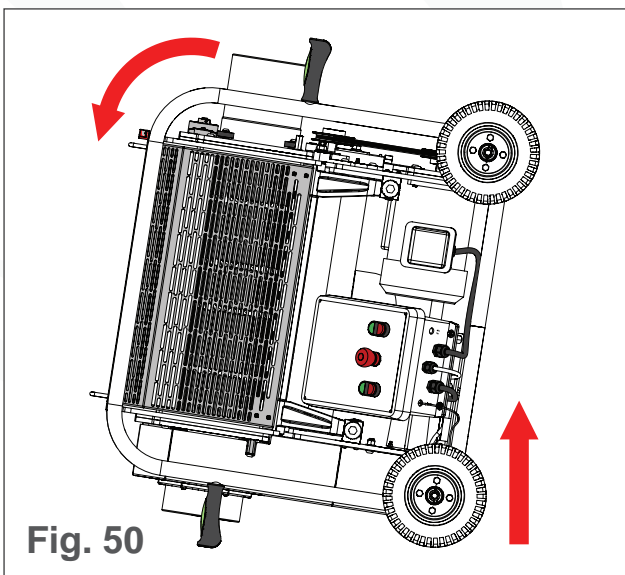
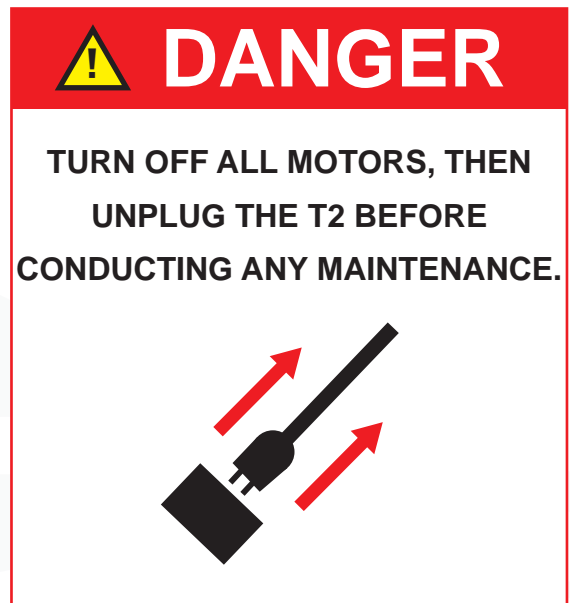

5. Loosen all four bolts on the blade motor plate (see Fig. 52).
6. Slide the motor up towards the tumbler (see Fig. 53).
7. Tighten one of the four bolts from step 4 to hold the motor in the up position.
8. Remove the old belt.
9. Install the new belt.
10. Rotate the machine back so all four wheels are on the ground.

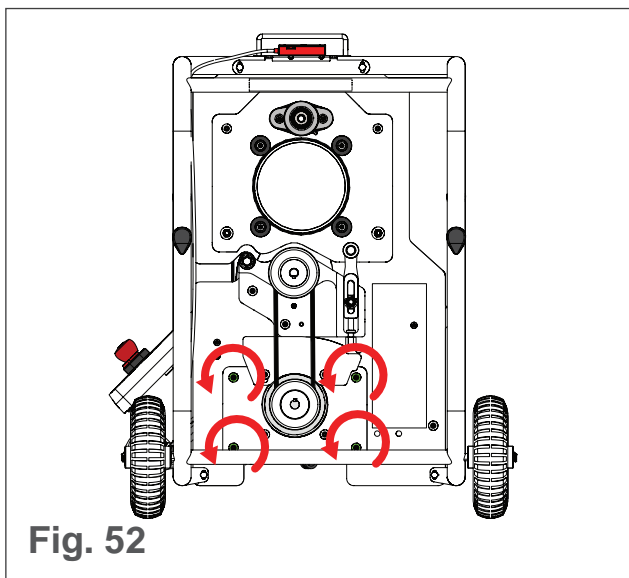

Fig. 52

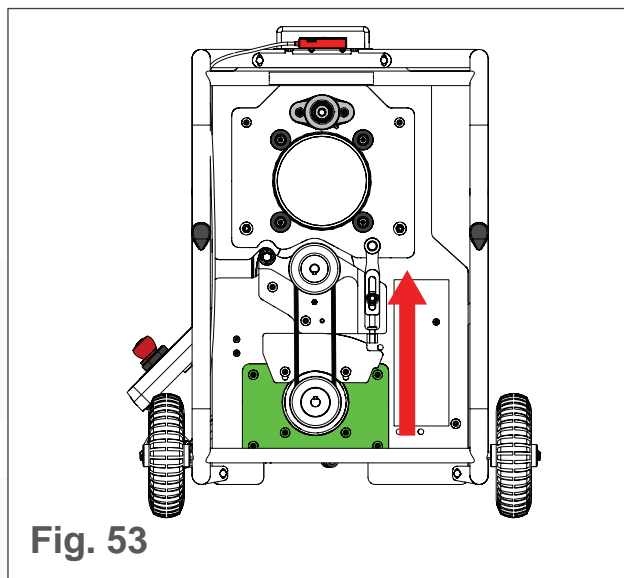

Fig. 53

11. Loosen the bolt tightened in step 6 to drop the motor.
12. Lift the blade motor from behind so it drops and gives the desired belt tension (see Fig. 54).
13. Tighten all four bolts on the blade motor plate.
14. Place the blade belt cover over the blade belt (see Fig. 55).
15. Insert and tighten the blade belt cover screws (see Fig. 55).



CAUTION

IF THE BELT CAN BE SQUEEZED SO OPPOSITE ENDS TOUCH, MORE TENSION NEEDS TO BE APPLIED.

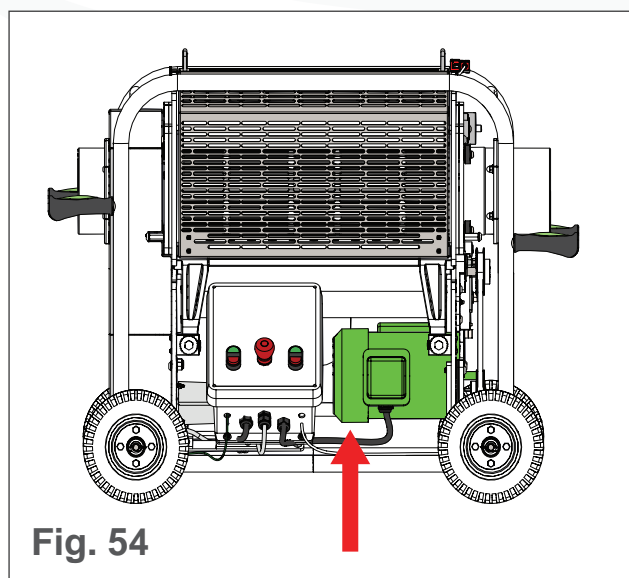

Fig. 54

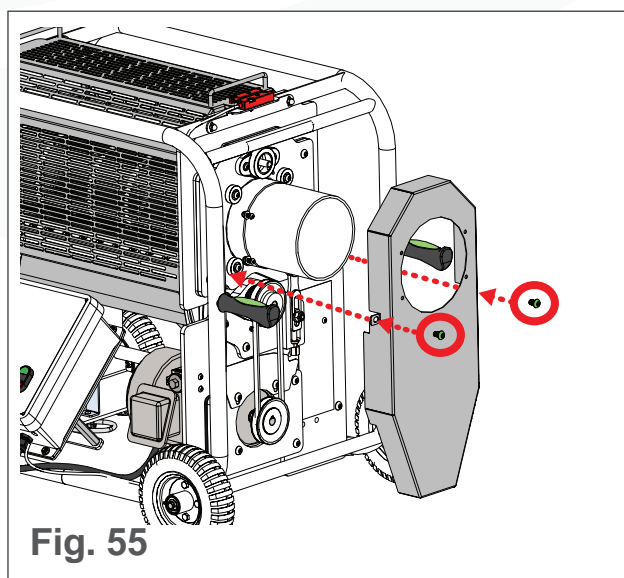

Fig. 55

Tumbler Belt Replacement

Over time, the tumbler belt will see natural wear. The tumbler belt should be replaced if it shows any signs of wear or physical damage. It is recommended to keep a spare tumbler belt for quick replacement. To replace the tumbler belt:

1. Remove the belt cover screws (see Fig. 56).
2. Remove the belt cover.
3. Remove the tumbler guide pin (see Fig. 57).
4. Rotate the tumbler guide out (see Fig. 57).



DANGER

TURN OFF ALL MOTORS, THEN UNPLUG THE T2 BEFORE CONDUCTING ANY MAINTENANCE.

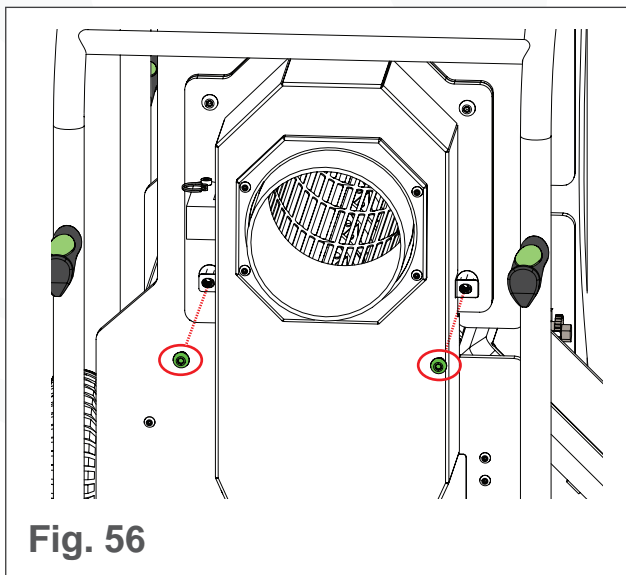
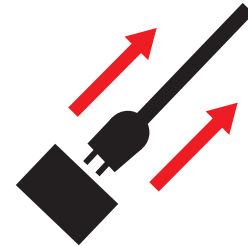

Fig. 56

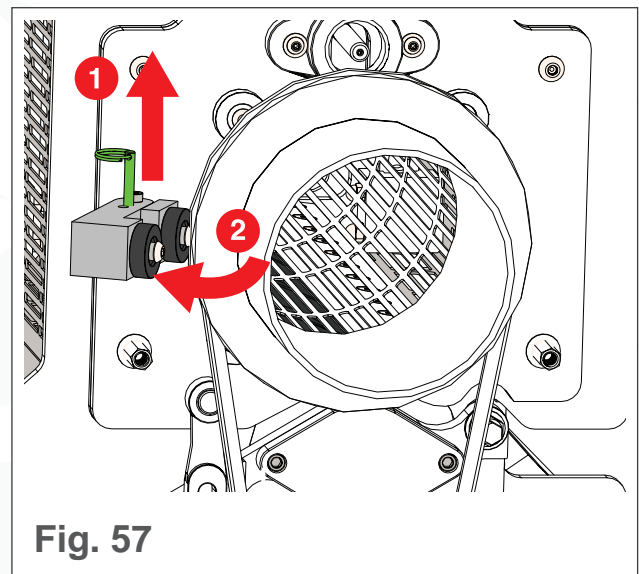
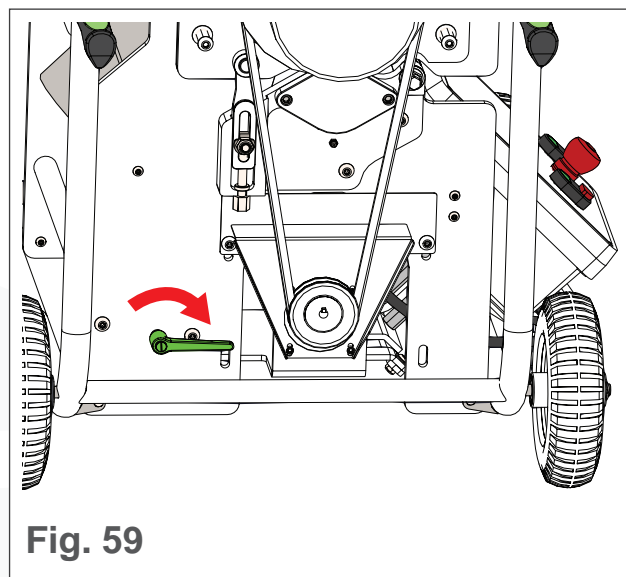
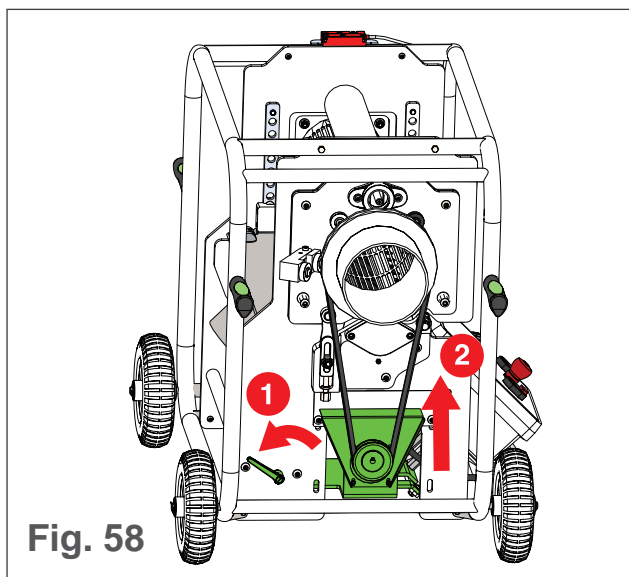
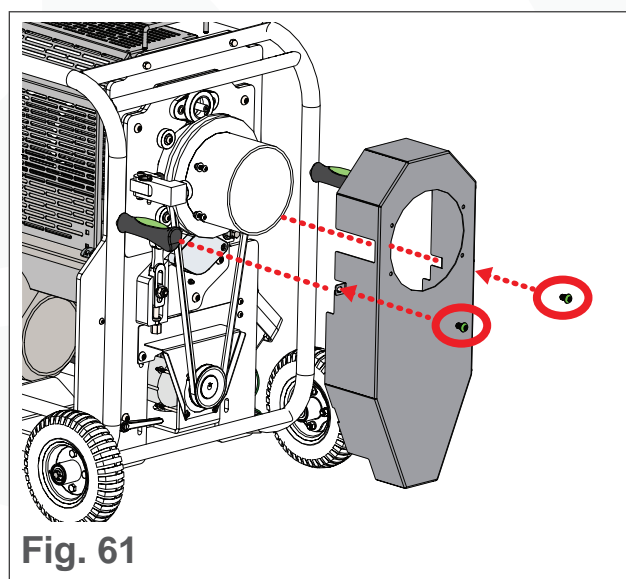
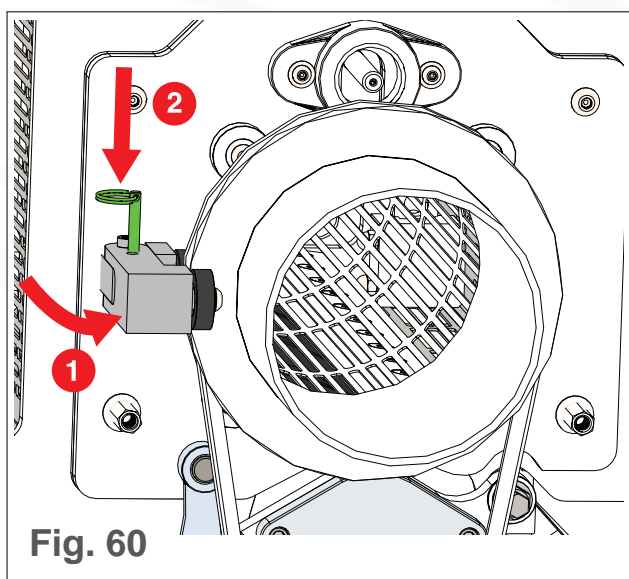

Fig. 57

5. Rotate the tumbler belt handle (see Fig. 58).
6. Lift the tumbler motor pulley (see Fig. 58).
7. Remove the tumbler belt.
8. Install the new tumbler belt.
9. Rotate the tumbler belt handle back (see Fig. 59).
10. Rotate the tumbler guide back to its lock position (see Fig. 60).



11. Insert the tumbler guide pin (see Fig. 60).
12. Place the tumbler belt cover over the tumbler belt (see Fig. 61).
13. Insert and tighten the tumbler belt cover screws (see Fig. 61).



When not in use, the T2 should be stored using the following guidelines to ensure the longevity of the machine.

Storage Guidelines

- Before storage, clean the T2 (see **Cleaning** on page 27).
- Before storage, apply an even coating of food grade oil to the bed knife and reel blade.
- Store the machine in a dry space.
- Store the machine in a safe space where it will not be knocked or inadvertently interfered with.
- Keep the machine out of reach of children and other unauthorized persons.



CAUTION

THE T2 MUST BE CLEANED
BEFORE STORAGE. IF NOT,
RESIDUE WILL HARDEN,
CAUSING REDUCED
PERFORMANCE AND EXTREMELY
DIFFICULT CLEANING.

TROUBLESHOOTING PROBLEMS

- The Tumbler Makes a Grinding Sound.
- The Blade Motor is Very Hot.
- A High Pitch Squeal Comes from the Blades
- The Circuit Breaker Keeps Tripping
- The Blade Motor Cycles on Startup (Slow Acceleration)
- There is Material Buildup on the Brush and Tumbler
- Product Comes Out of the T2 Unprocessed
- Suction from the Vacuum Seems Weak
- Product is Not Exiting the Tumbler
- The Motors Won't Start
- The Motor Start Buttons Light Up, but The Motor Does Not Start
- The Tumbler is Contacting the Blades

The Tumbler Makes a Grinding Sound

Possible Causes:

- The rollers are damaged.
- The tumbler is damaged.
- The tumbler is installed incorrectly.

Solutions:

- Spin the rollers to see if they spin freely and are intact. If the rollers are damaged, replace them.
- If the tumbler is not significantly damaged, manually bend the tumbler back into shape.
- Readjust the tumbler plate further from the blades.



DANGER

TURN OFF ALL MOTORS, THEN UNPLUG THE T2 BEFORE CONDUCTING ANY TROUBLESHOOTING SOLUTIONS.

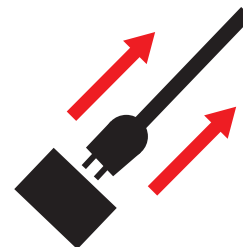

The Blade Motor is Very Hot

Possible Causes:

- The blade motor is run for long periods.
- The blades contact each other too much.
- The blades do not contact each other enough.
- The blades are dirty.

Solutions:

- The blade motor will get hot if run for long periods of time. This is normal. The blade motor is thermally protected and will turn off if it becomes too hot. If this occurs allow it to cool and then restart the T2.
- Ensure the blades have proper contact.
- Clean the blades.

A High Pitch Squeal Comes from the Blades

Possible Causes:

- The bearings are worn out.
- The blades are dirty.
- The blades contact each other too much.

Solutions:

- Disassemble the machine, and spin the blade by hand, checking for any damage to the blades, proper contact, and that the bearings are spinning smoothly. If no damage is found:
 - Clean the blades.
 - Reset the blades for light contact (see **Adjusting the Blade** on page 31).

- If cleaning and resetting the blades does not solve the problem, call technical support to replace the bearings.

The Circuit Breaker Keeps Tripping

Possible Causes:

- The extension cord is too long.
- The extension cord is undersized.
- The circuit breaker is not sized properly for the T2 and Trim Saver or Leaf Collector.
- The blades are dirty.

 **DANGER**

DO NOT INCREASE THE CIRCUIT BREAKER SIZE ABOVE 20A/120V (NORTH AMERICA) OR 10A/230V (EUROPE).

Solutions:

- Use a rated 12 AWG extension cord (no longer than 25ft/7.6m).
- Ensure the machine is not sharing a circuit with other devices.
- Run the vacuum and blade on separate circuit breakers.
- Clean the blades.

The Blade Motor Cycles on Startup (Slow Acceleration)

Possible Causes:

- The voltage is too low.
- Excessive distances from the transformers and/or electrical panels are reducing the voltage.
- The extension cord is too long.
- The extension cord is undersized.
- The blades are adjusted too tight.

- The blade belt is too loose or damaged.

Solutions:

- Change the power input.
- Use a rated 12 AWG extension cord (no longer than 25ft/7.6m).
- Adjust the blades (see **Blade Adjustments** on page 30).
- Tighten the blade belt.

There is Material Buildup on the Brush and Tumbler

Possible Causes:

- The T2 is operating in too warm of an environment.
- The brush is not lubricated enough during wet trimming.
- The T2 is not cleaned frequently enough.

Solutions:

- Operate the T2 in a colder environment.
- Lubricate the brush frequently during wet trimming (see **Step 4: Feed the T2** on page 15).
- Clean the T2 after each use.

Product Comes Out of the T2 Unprocessed

Possible Causes:

- The suction is too low.
- The blades are not on.
- The blades are improperly adjusted.

- The tumbler is too full.
- The tumbler is improperly adjusted.

Solutions:

- Ensure all the components are on and suction is high (see **Suction from the Vacuum Seems Weak**).
- Turn the blades on.
- Adjust the blades so there is light contact between the blades.
- Keep the tumbler less than half full.
- Adjust the tumbler closer to the blades. If this does not work, replace the tumbler.
- Give lower density product a second pass through the T2.

Suction from the Vacuum Seems Weak

Possible Causes:

- The hose is blocked.
- The vacuum impeller has buildup around it.
- The Vacuum Bypass is allowing too much airflow.
- If using the Trim Saver:
 - The gasket connections have leaks.
 - The filter bag is dirty.
 - The vacuum outlet is placed too close to a wall.

Solutions:

- Ensure nothing is blocking the hose.
- Unplug the vacuum and remove the inlet housing to clean inside the impeller housing.
- Close the Vacuum Bypass.

- Inspect the Trim Saver gaskets for leaks (see the Trim Saver manual for gasket locations).
- Clean the filter bags.
- Place the vacuum outlet at least 4' from wall

Product is Not Exiting the Tumbler

Possible Causes:

- The suction is too high.
- The T2 is not inclined enough.

Solutions:

- Purchase a Vacuum Bypass to reduce the suction (for details on the Vacuum Bypass, see **Accessories** on page 52).
- Increase the machine's incline.

Possible Causes:

- The emergency stop light is on.

Solutions:

- Push the emergency stop button in, and then pull it out.
- Remove the tumbler guard and reinstall it.
- Check the safety interlocks are installed in the correct orientation (see Fig. 62) . The top

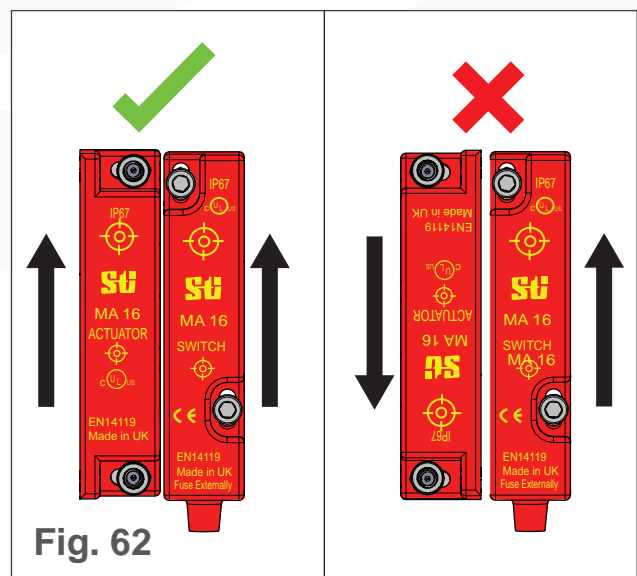

Fig. 62

of both red sensors have text. Ensure the text is facing the same direction on both sensors and the sensors are no more than 1/8" apart (see Fig. 62).

- If the red light is still on or no lights come on with the above solutions, call technical support.

The Motor Start Buttons Light Up, but the Motor Does Not Start

Possible Causes:

- The motor has overheated and is in cool down mode.
- The blades need cleaning or adjustment.
- Improper tension has been placed on the blade belt.
- There is a loose electrical connection inside the box.

Solutions:

- Wait for the motor to cool down.
- Clean and adjust the blades (see **Blade Adjustments** on page 30).
- Adjust the blade belt tension (see **Blade Belt Replacement** on page 35).
- If a loose electrical connection is suspected, call technical support (for contact details, see page 54).

The Tumbler is Contacting the Blades

Possible Causes:

- The tumbler is improperly adjusted.
- The tumbler is damaged.

Solutions:

- Attempt to locate the contact point. Once the contact point is found, adjust the tumbler clear of the interference (see **Tumbler Adjustments** on page 33).
- Replace the tumbler.

WARRANTY INFORMATION

Keirton will replace any parts proven defective in material or workmanship without charge for a period of ten years.

The warranty period will begin on the date the machine is purchased by the initial purchaser. The T2 warranty defects can be remedied at any authorized service dealer or directly by Keirton. Any original parts deemed to be defective will be replaced free of charge. Keirton reserves the right to use any manufacturer approved replacement part for warranty repair.

If a warranty repair is required, please contact Keirton at **1-888-254-3204** or **support@keirton.com** and provide the following information:

- Model and serial number (located on underside of the T2)
- Proof of purchase date
- Copy of the original Warranty Registration Card (unless registration was completed online)
- Details of the defect or problem (including photos and/or video).

Pending approval from Keirton, the machine or defective part must then be returned to Keirton for analysis and replacement. **Do not return the machine to the place of purchase for repair or warranty claims unless you have been authorized by Keirton to do so.** The place of purchase can only sell replacement parts and will not repair warranty issues unless it is noted as an authorized repair dealer and has been authorized to work on your machine.

You may be denied warranty coverage if your machine has failed due to:

- Abuse
- Accidental damage
- Improper maintenance
- Improper electrical connection

- Neglect
- Normal wear
- Unapproved modifications including use of unapproved replacement parts.

Keirton assumes no risk and shall be subject to no liability for damages or loss resulting from the specific use or application made of the product. In no event will Keirton be liable for any special, incidental, or consequential damages (including loss of use, loss of profit, and claims of third parties) however caused, whether by negligence of the manufacturer or otherwise. If you have any questions regarding your warranty rights and responsibilities, please contact Keirton.

The T2 is intended for use on legal aromatic herbs and hops. Please check all municipal, provincial/state, and federal laws and regulations before using the T2. Keirton does not promote or condone the use of the T2 in any way that may be deemed illegal.

Allow only persons who understand this manual to operate the T2. Keirton claims no liability for any damage or injury that results from the use of the T2 by persons who have not read and understood the cautions, warnings, and danger notices contained in this manual or through any misuse of the T2. You are responsible for your safety while operating this machine. **Please keep yourself safe!**

North American Specifications

Product Number	Product Number	02-10006A
Certifications	Certification	CSA/UL
Dimensions	Machine Height	34.5in/876mm
	Machine Length	38.1in/968mm
	Machine Width	27.5in/699mm
	Tumbler Diameter	6in/101mm
	Tumbler Slots (standard tumbler)	50 x 0.25in/6.4mm
	Cut Height	0.04in/1mm
Electrical Requirements	Circuit Breaker Requirements	20A/120V
	Connector Plug	NEMA L5-20P* (see Fig. 63)
	Current	15.5A
	Extension Cord Requirements	12AWG (minimum AWG)
		25ft/7.6m (maximum length)
Input Voltage	120V, 60Hz	
Motors	Blade Motor	1HP
	Tumbler Motor	1/30HP
Speed	Blade Speed	1750RPM
	Tumbler Speed	75RPM
Weight	Machine Weight	215lbs/97.5kg

*North American T2s come with a water-resistant NEMA L5-20P locking connector and an adapter for the NEMA 5-20P (see Fig. 64).

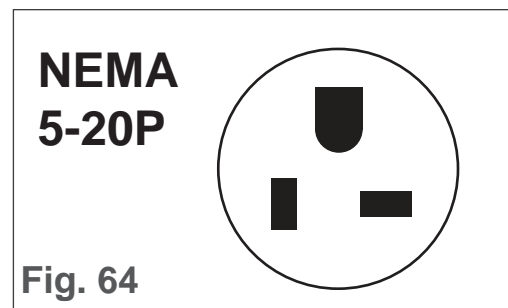
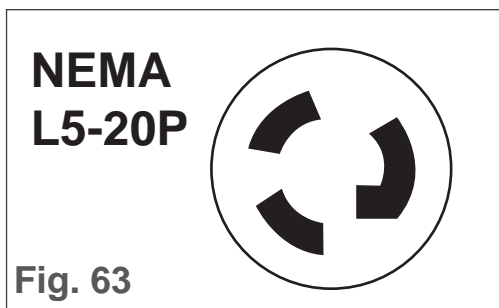

European Specifications

Product Number	Product Number	02-10021A
Certifications	Certification	CE
Dimensions	Machine Height	876mm/34.5in
	Machine Length	968mm/38.1in
	Machine Width	699mm/27.5in
	Tumbler Diameter	101mm/6in
	Tumbler Slots (standard tumbler)	50 x 6.4mm/0.25in
	Cut Height	1mm/0.04in
Electrical Requirements	Circuit Breaker Requirements	10A/230V
	Connector Plug	CEE 7/7 (see Fig. 65)
	Current	8A
	Extension Cord Requirements	12AWG (minimum AWG)
		25ft/7.6m (maximum length)
Input Voltage	230V, 50Hz	
Motors	Blade Motor	750W
	Tumbler Motor	25W
Speed	Blade Speed	1750RPM
	Tumbler Speed	75RPM
Weight	Machine Weight	97.5kg/215lbs

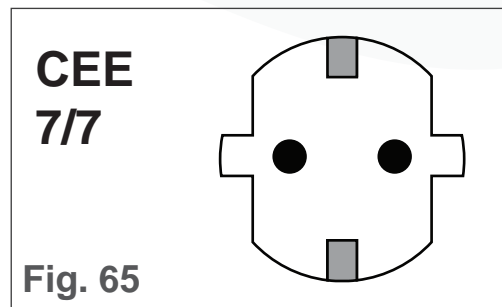

Conveyors

Standard Feed Conveyor	26-0001
Standard QC Conveyor	26-0002
Standard Conveyors Extension Kit	27-0006
Stainless Steel Feed Conveyor	26-10018A
Stainless Steel QC Conveyor	26-10019A
Extended Height Feed Conveyor	26-0102
Extended Height QC Conveyor	26-0106

Hopper

T2 Hopper	24-0135
------------------	---------

Rails

Twister T2 Single Rail	24-0400
Twister T2 Rail Extension*	24-0401
Twister T2 Triple Rail System	24-9036
Twister T2 Quad Rail System	24-9033

**The Twister T2 Rail Extension attaches to the Twister T2 Single Rail to support two T2s.*

Spare Parts

Trim Saver Nylon (70 Micron) Filter Bag	23-0217
Trim Saver White Mesh (40 Micron) Filter Bag	23-0247
Leaf Collector Filter Bag	23-0197
Leaf Collector Collection Bag	23-0133
T2 Tumbler - Standard (1/4" Slots)	24-9033
T2 Tumbler - Narrow (3/16" Slots)	24-0003

Spare Parts (continued)

T2 Blade Belt	19-0008
T2 Tumbler Belt	19-0009

Vacuums and Bypass

Trim Saver Vacuum	23-0200
Leaf Collector Vacuum	23-0117
Vacuum Bypass	23-0255

CONTACT US

Keirton Technical Support is available between 7 a.m. and 7 p.m. Pacific Standard Time, seven days a week at:

- **1-888-254-3204**
- **support@keirton.com**